



Installation manual

SMART BRAKE MODULE

Compatible with all motorcycles with 12 V or 6 V bulb voltage. Also compatible with LED, halogen or HID brake lights. With Smart Brake Module (SBM) installed, your bike will turn on the brake light when engine braking. SBM will calibrate itself after each ignition. After the SBM calibrates, you will see a short flash on your brake light.

1. Find the wires listed in the chart in the place where you would change the bulb in your tail light
2. Follow those wires and find a suitable place to attach the SBM unit
3. Attach TAB connectors on the motorcycle harness according to the chart
4. Plug the Smart Brake Module cables into the TAB connectors
5. Choose your option: Flashing or Steady light when decelerating
6. Firmly attach the SBM unit on the motorcycle chassis
7. Turn on your motorcycle and enjoy your ride

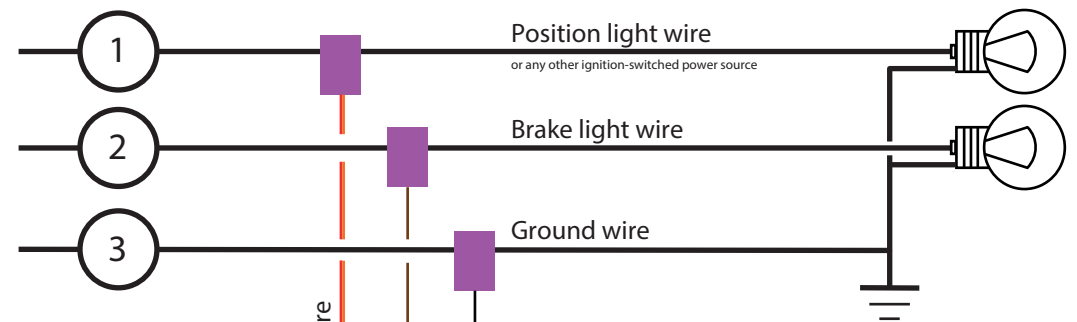

How to choose between two operating modes:

Steady
brake light
Logo Up



Flashing
brake light
Logo Down



Attach the SBM to motorcycle chassis:

- > Arrow must be facing in driving direction
- > SBM must be perfectly levelled for best accuracy
- > Logo facing up or down (see operating modes)
- > Use zip ties to secure the SBM on the chassis
- > Avoid attaching near any heat sources

ST2 SMART BRAKE MODULE			Yamaha	Honda	Kawasaki	Suzuki	Triumph	BMW	Aprilia	Moto Guzzi
Power	Red / Orange	To motorcycle	① Blue	Brown / White	Red	Brown	Yellow Red	Grey / Red	Yellow Red	Yellow Green
Signal	Brown		② Yellow	Green / Red	Grey Green Blue	White / Black	Green / Purple Green Blue	Grey / Black	Yellow / Green Grey	Green / Yellow Green / White
Ground	Black		③ Black	Green	Black / Yellow	Black / White	Black	Brown	Blue Black	Blue Black

IMPORTANT! Colours listed in the chart above are informative and may not be the same as on your motorcycle. Please check the correct colours in your service / repair manual before starting the installation.

Disclaimer

To the maximum extent permitted by applicable law neither Moyalysse d.o.o. nor its suppliers, its subcontractors, its affiliates, officers, directors, employees, dealers or agents shall be liable to you or to any third party for any incidental damage including personal injury or any other damages, whether direct, special, incidental, indirect or consequential arising out of or related to:

- > Smart Brake Module not working correctly due to improper calibration of the system and/or any other usage that is not in comply to Smart Brake Module user manual.
- > Damage made on a motorcycle due to improper installation and/or improper use of Smart Brake Module.
- > Brake light not working due to improper installation or calibration.
- > Smart Brake Module not indicating deceleration on brake light when decelerating with an engine or indicating a deceleration when it, in fact, didn't occur.

Smart Brake Module is a device that assists motorcyclist to indicate deceleration when engine braking or downshifting. Smart Brake Module can detect deceleration and turn on brake light when deceleration occurs. Due to various driving styles and motorcycle types company Moyalysse d.o.o. can take no responsibility if Smart Brake Module doesn't detect deceleration and consequently doesn't turn on the brake light. Correct usage of brake light is motorcyclist responsibility, and Smart Brake Module device is meant only to assist rider with deceleration indication.

Improper installation or operation of Smart Brake Module

Smart Brake Module device has to be installed according to the Moyalysse installation manual. If you are not sure about any part of installation manual or/and your motorcycle wiring scheme, please contact Moyalysse d.o.o. at support@safer-turn.com

Warranty

Limited Warranty applies to physical goods, and only for physical goods, purchased from Moyalysse d.o.o. (the "Physical Goods"). Limited Warranty covers any defects in material or workmanship under normal use during the Warranty Period. During the Warranty Period, Moyalysse d.o.o. will repair or replace, at no charge, products or parts of a product that proves defective because of improper material or workmanship, under normal use and maintenance. Moyalysse d.o.o. will either repair the Product at no charge, using new or refurbished replacement parts. The Warranty Period for Physical Goods purchased from Moyalysse d.o.o. is 730 days from the date that the product was shipped.

A replacement Physical Good or part assumes the remaining warranty of the original Physical Good or 180 days from the date of replacement or repair, whichever is longer. This Limited Warranty does not cover any problem that is caused by conditions; malfunctions or damage not resulting from defects in material or workmanship. To obtain warranty service, you must first contact our support@safer-turn.com to determine the problem and the most appropriate solution for you.

Moyalysse d.o.o., Vojkova cesta 63, 1000 Ljubljana, Slovenia - EU, e-mail: support@safer-turn.com