

MONTAJE, ASSEMBLY, MONTAGE, MONTAGGIO

REF. KAWASAKI (5 TORNILLOS, 5 SCREWS) (5 SCHRAUBEN, 5 VISSES)

Nº1  M5X30 DIN 912 1UDS

Nº2  M5X35 DIN 7380 2UDS

Nº3  M5X20 DIN 912 2UDS

 ALLEN: 4, 3.



¡ TORQUE, PAR DE APRIETE, LOCKED TORQUE !

M5 - 5 Nm

NOTA: No garantizamos contra la rotura debido al sobreapretamiento de los tornillos.

NOTE: We do not guarantee against breakage due to overtightening of screws.

ATTENTION: Nous ne garantissons pas contre la rupture en raison du surresserrement de vis.

ATTENZIONE: Noi non garantiamo contro rottura a causa di stringere eccessivamente di viti.

ACHTUNG: Wir übernehmen keine Haftung bei Brüchen durch zu festes Anziehen der Schrauben

Motoplasic S.A.
Molino de la Sal, 1
08400 Granollers
Barcelona, España
Tel: 93.849.06.33 Fax: 93.849.09.88
E-mail: info@motoplasic.com

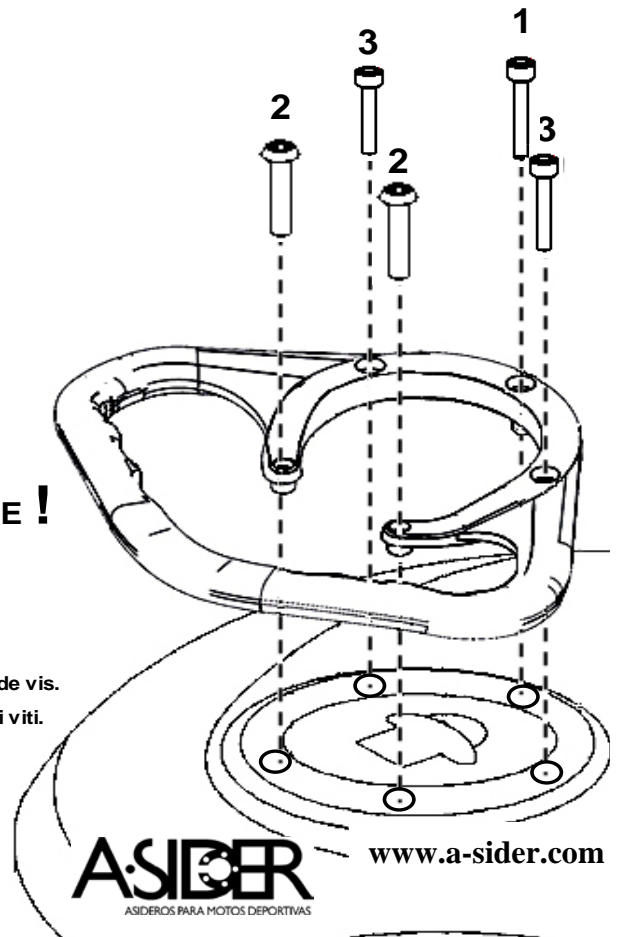

MONTAJE, ASSEMBLY, MONTAGE, MONTAGGIO

REF. KAWASAKI (5 TORNILLOS, 5 SCREWS) (5 SCHRAUBEN, 5 VISSES)

Nº1  M5X30 DIN 912 1UDS

Nº2  M5X35 DIN 7380 2UDS

Nº3  M5X20 DIN 912 2UDS

 ALLEN: 4, 3.



¡ TORQUE, PAR DE APRIETE, LOCKED TORQUE !

M5 - 5 Nm

NOTA: No garantizamos contra la rotura debido al sobreapretamiento de los tornillos.

NOTE: We do not guarantee against breakage due to overtightening of screws.

ATTENTION: Nous ne garantissons pas contre la rupture en raison du surresserrement de vis.

ATTENZIONE: Noi non garantiamo contro rottura a causa di stringere eccessivamente di viti.

ACHTUNG: Wir übernehmen keine Haftung bei Brüchen durch zu festes Anziehen der Schrauben

Motoplasic S.A.
Molino de la Sal, 1
08400 Granollers
Barcelona, España
Tel: 93.849.06.33 Fax: 93.849.09.88
E-mail: info@motoplasic.com

