

## SHAD brake light kit for moto-detail top box adapter plate (order no. 10059259)

The additional brake light for the SHAD/moto-detail top box helps to increase the visibility of your bike when in traffic and make riding safer. In accordance with European approval regulations, they can be fitted to any bike that has complete EC type approval. This is how you can recognise an EC entry in your bike's paperwork (The following information relates to vehicles registered in Germany. Please observe the regulations which apply in your own country.):

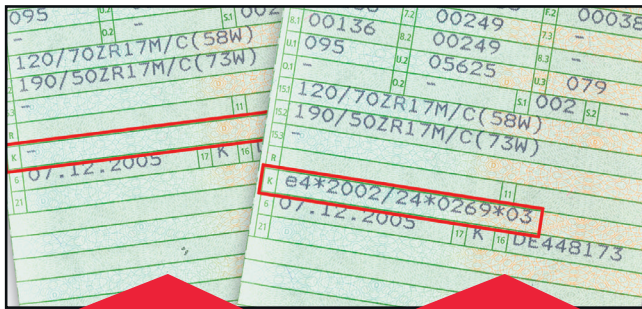

Fig. 1: Motor vehicle registration certificate, Part 1, without EC entry

Fig. 2: Motor vehicle registration certificate, Part 1, with EC entry

On older bikes that have been licensed according to German law, the brake light can be fitted provided all the lighting equipment has EC approval (i.e. an „E“ mark on the glass of both the headlight and the tail light, the license plate light, and the turn indicators). It is not approved for use on vehicles licensed according to German law where the lighting equipment still has the „old“ German test mark (the „test snake“) or other test marks (classic, vintage).

The brake light must be fitted horizontally in the middle of the vehicle at a height of at least 250mm and no more than 1500mm. A maximum of two brake lights may be fitted to one bike. Lamps consisting, for instance, of two brake light bulbs in a single common housing are deemed to be one unit. If the above conditions are satisfied, the additional brake light may be used on the vehicle without TÜV approval. A written report is also not required, as the „E“ mark on the brake lights is considered by the regulatory authorities to be the only necessary proof of legality.

### Installation:

Take the box off the top box plate by opening and unlatching it. Pull up the seat, and look for the cable leading to the tail light. Take the plug(s) off the tail light. With the ignition switched, lock one of the brake levers on (front or rear), so that a brake light switch is on continuously. (For example, hold the brake lever against the handlebar with a strap.) Now make use of the test lamp, and find out which wire in the harness carries electricity to the tail light (connect the test lamp to earth, and use a test probe to look for the positive wire to the brake light). Mark the cable. Look for the negative line to the brake light (connect the test lamp to the positive pole of the battery – it will light up when you hold the test probe against the negative cable) – and mark this wire too. If the tail light does not have a negative wire it is connected through earth, and you will have to create an earth connection for the SHAD brake light as well. Now switch the ignition off again, and release the brake lever.

If it is not already attached there, put the top box plate on its support and lay the cable in such a way that it reaches the cable to the tail light. Try to keep the cable as covered as possible by passing it, for instance, under the rear faring. Under no circumstances must the cable touch the exhaust, the rotating rear wheel or any other part that moves or gets hot, even when the rear suspension of the bike is retracted. Screw the SHAD brake light onto the top box plate. Now connect the cables. Cut the positive wire to the tail light that you marked earlier on. Remove about 5mm of insulation from the cable ends. Use suitable crimping tongs (e.g. Louis Item 10003916) to crimp on two male Japanese connectors (e.g. Louis Item 10032033). You can now insert the red positive wire of the SHAD brake light between them. Do the same for the negative wire. If there is no negative wire, make a connection between the black, negative cable of the SHAD brake light and the frame of the bike. If necessary, fasten the cables to the frame or tail of the bike using cable ties. Then check the function of the brake light by turning on the ignition and the main light, and operating the brake. If the brake light at the rear no longer comes on, or if your tail light is brighter than before, you have mixed up the positive wires of the brake light and the tail light.

## SHAD brake light kit for moto-detail top box adapter plate (order no. 10059259)

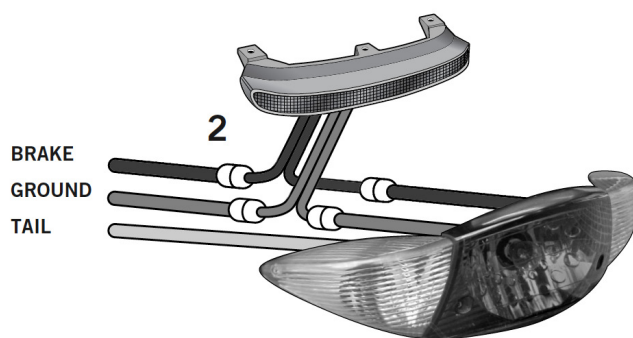
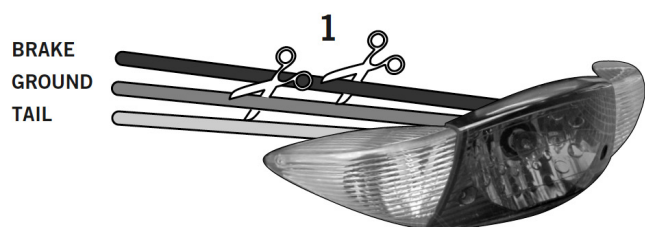

Since this is a universal product and not intended just for one particular vehicle, it is important to make sure that it is suitable for your type of vehicle before you use the product for the first time. Always follow the instructions in your vehicle operator's manual and the directions of the vehicle manufacturer. This is essential, as improper use of this product or its unsuitability for a vehicle could impair the safety and/or condition of the vehicle.

Make sure that the brake light is not in contact with any raised part of the exhaust system.

Be careful to ensure that the cables cannot touch the wheel or the exhaust, even when the rear suspension of the bike is retracted.

Take care to see that the cable connection is solid, with properly crimped cable terminals and a reliable plug-in connection. After fitting the light, check the function of your tail light and brake light, as these are very important for safe riding.