

Technische Daten - Hinterrad Type A 1760; 041, 078

Yamaha YZF-R1
Yamaha YZF-R1M

Fahrzeugtyp: RN32, RN49, RN65 (2015 -)
Fahrzeugtyp: RN49, RN65 (2018 -)

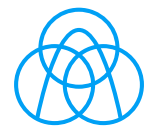

thyssenkrupp

Größe	6,0" x 17"
Gewicht (komplett)	3,7 – 3,9 kg

Lieferumfang	
①	Hinterrad
②	Distanzhülse (Original Yamaha)
③	Radlager (L/R) 60/28 2RS/C3
④	Sprengring 52x2 mm (DIN 472)
⑤	Wellendichtring L 35x52x8 mm
⑥	Wellendichtring R 40x52x6 mm
⑦	Abstandshülse R
⑧	Winkelventil

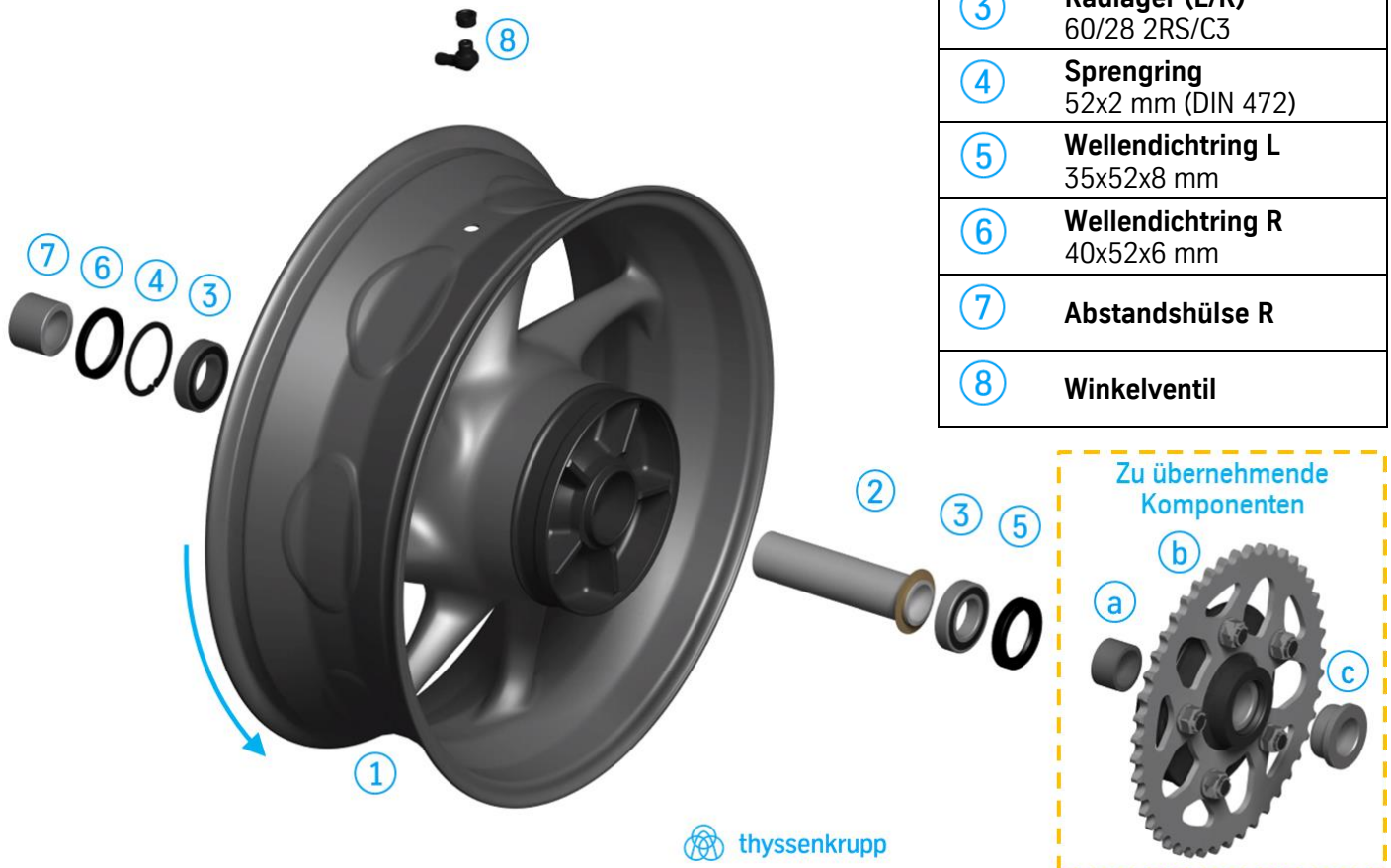

thyssenkrupp

Weitere technische Hinweise

Befestigungsschrauben Bremsscheibe:	Drehmoment gemäß Angaben Fahrzeughersteller
Winkelventil:	Drehmoment 8 Nm
Zu übernehmende Komponenten vom Originalrad:	Ruckdämpfer (nicht abgebildet) Distanzhülse Kettenradträger links (a) Kettenradträger komplett (b) Abstandshülse links (c) Bremsscheibe rechts (nicht abgebildet) ABS-Sensorring rechts (nicht abgebildet) Schrauben Bremsscheibe (nicht abgebildet) Schrauben ABS-Sensorring (nicht abgebildet)

ACHTUNG:
Folgende Montage beachten:

Eine fehlerhafte- oder Nicht-Montage von Distanzhülse Kettenradträger links (a) führt zu einem irreparablen Schaden an der Felge!

Technical details – rear wheel type A 1760; 041, 078

Yamaha YZF-R1 vehicle type: RN32, RN49, RN65 (2015 -)
 Yamaha YZF-R1M vehicle type: RN49, RN65 (2018 -)

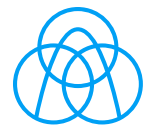

thyssenkrupp

Size	6.0" x 17"
Weight (total)	3.7 – 3.9 kg/ 8.14 – 8.58 lbs

Scope of delivery	
①	Rear wheel
②	Distance sleeve (Original Yamaha)
③	Wheel bearing (L/R) 60/28 2RS/C3
④	Snap ring 52x2 mm (DIN 472)
⑤	Shaft seal L 35x52x8 mm
⑥	Shaft seal R 40x52x6 mm
⑦	Distance spacer R
⑧	Angled valve

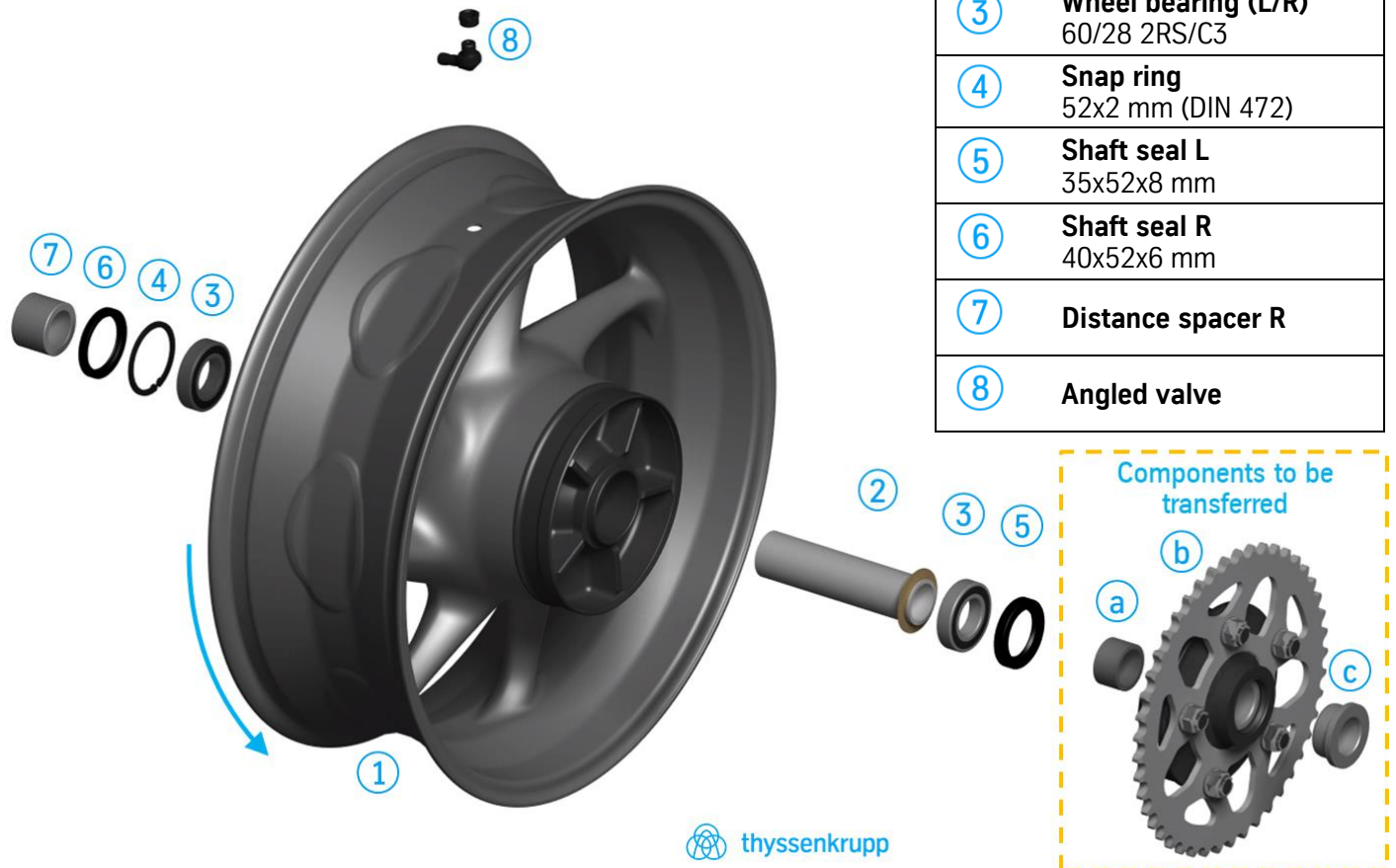

thyssenkrupp

Further technical notes

Fixing bolts (brake disc):	Torque according to instructions of vehicle manufacturer
Angled valve:	Torque 8 Nm
Original wheel components for assembly:	Shock damper (not shown) Distance spacer sprocket adapter left (a) Complete sprocket adapter (b) Distance spacer left (c) Brake disc (not shown) ABS sensor ring right (not shown) Fixing bolts brake disc (not shown) Fixing bolts ABS sensor ring (not shown)
ATTENTION: Installation absolutely necessary!	Failure to install / to leave the distance spacer of sprocket adapter left (a) will result in irreparable damage to the wheel!