



Fitting Instruction

Part-No. : **110H090**
Product : **Rear Set**
Vehicle Manufacturer : **Honda**
Model : **CBR 900RR 2000 - 2001**

Important:

Read this instruction manual carefully and mind all warnings and tips. You should do this work only if you're qualified; otherwise we recommend this mounting to be done by a qualified workshop. Improperly mounting of this kit can reduce the driveability of the motorcycle and may be a risk to your health and life.

Special works are marked with the following signs. Please take special care on these works.



Warning! Important mounting instruction. It shows risks to your life and health.



Tips for mounting and maintenance or to avoid damage.

Fitting:

Remove stock rear sets. The following original parts will be used for your new rear set: Brake light switch with its bracket, spring and bolt, brake pedal retain spring, both heel protectors and the bolts to fix the hanger.



Rear sets are pre-assembled but all screws are not tightened! Always use locknuts or proper amount of medium thread-locking adhesive (e. g. Loctite 243). All details of assembling are shown on the backside drawing. All parts are welded into their bags as they belong together.



Loose the fitting on the brake cylinder slightly and turn it a little bit outward, then tighten it again. It may be necessary to pull the brake hose through the guidance towards the brake cylinder.

The tightening torques for connections to the frame refers to the manufacturer's instructions. Use the following torques for all other bolted connections:

M5	=	6Nm	=	4.43lbf ft
M6	=	10Nm	=	7.38lbf ft
M8	=	20Nm	=	14.75lbf ft
M10x1.25	=	30Nm	=	22.13lbf ft



After installing your new rear set, **test brake and gear shifting indoor. If anything is not operating properly or braking efficiency is poor, testing on the road may result in death or serious injury!**

Maintenance:



Periodically proof all functions during service intervals. Use **particle free (no MoS₂)** lithium or barium soap grease to maintain lever bushings.

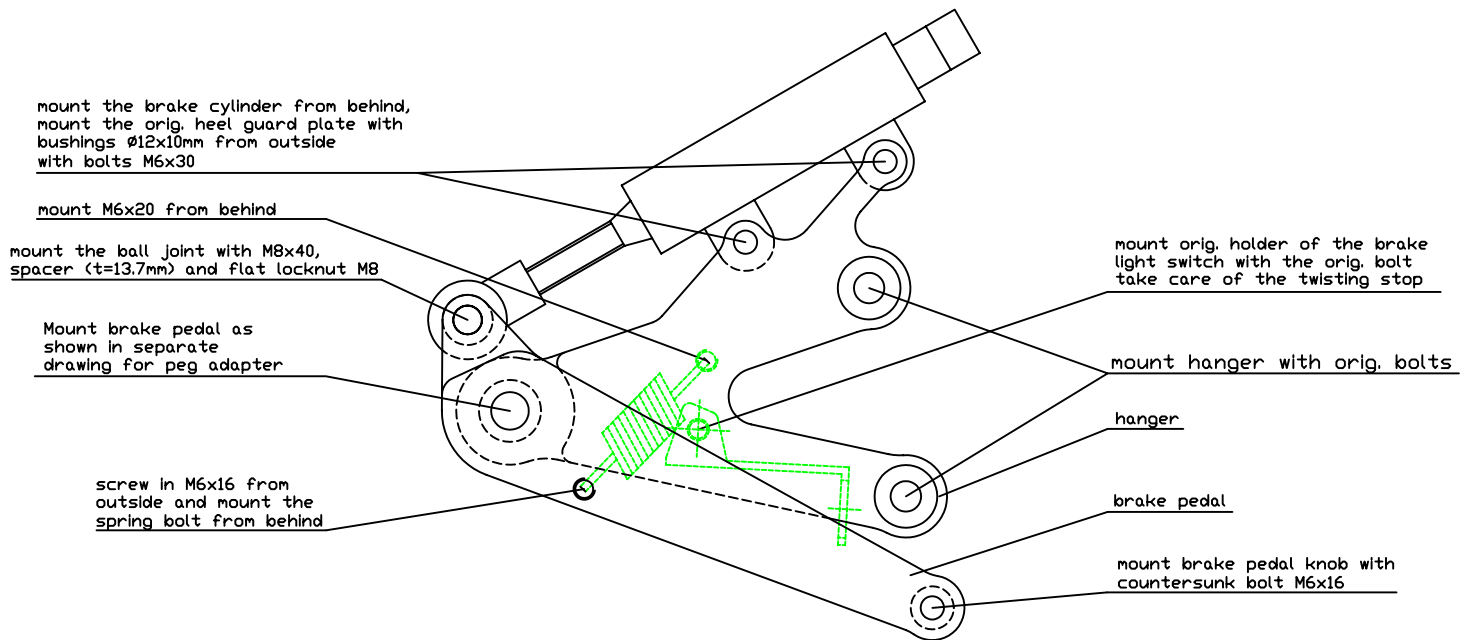

rear set CBR 900 RR '00-01
mounting drawing, brake

LSL-Motorradtechnik, 11.05.01

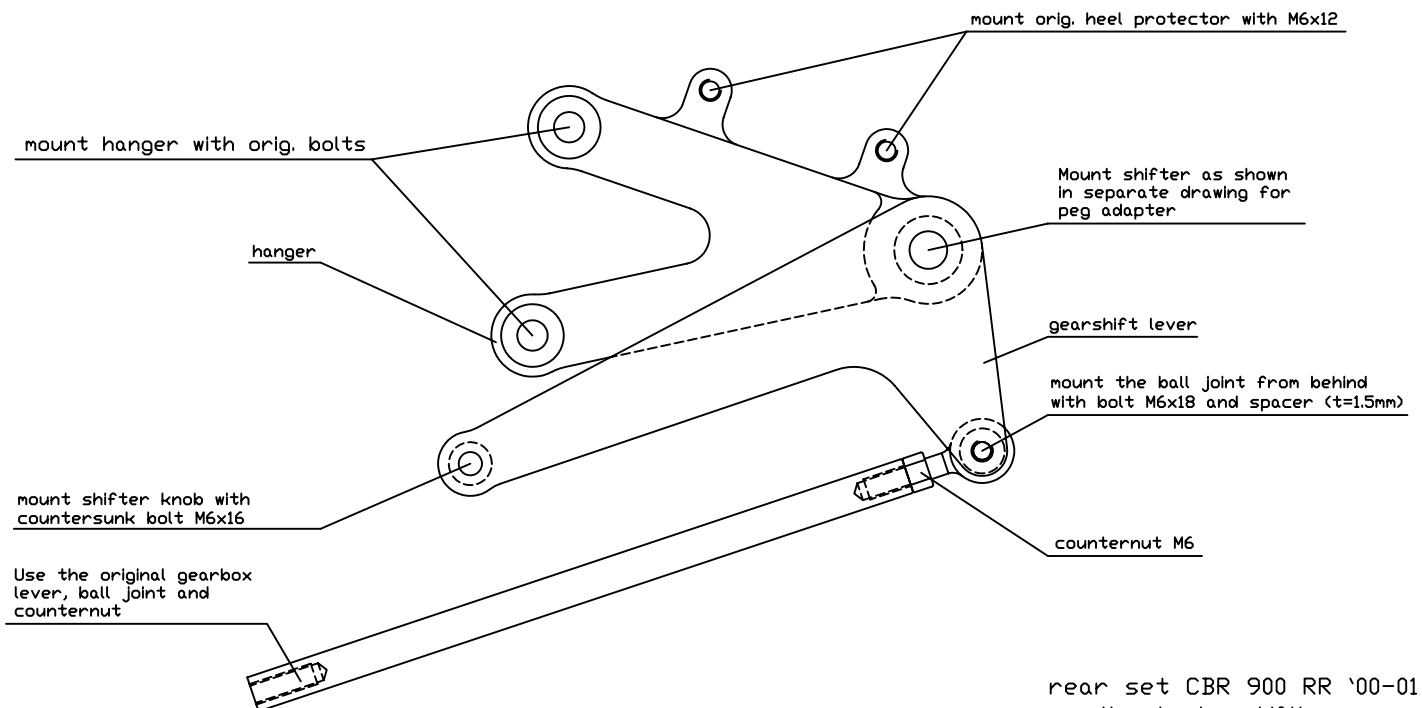

rear set CBR 900 RR '00-01
mounting drawing, shifting

LSL-Motorradtechnik, 11.05.01

