



Fitting Instruction

Part-No. : 118Y120
Product : Rear Set 2-Slide
Manufacturer : Yamaha
Model : YZF-R1 2009 →

Important:

Read this instruction manual carefully and mind all warnings and tips. You should do this work only if you're qualified; otherwise we recommend this mounting to be done by a qualified workshop. Improperly mounting of this kit can reduce the driveability of the motorcycle and may be a risk to your health and life.

Special works are marked with the following signs. Please take special care on these works.



Warning! Important mounting instruction. It shows risks to your life and health.



Tips for mounting and maintenance or to avoid damage.

Fitting:

Remove stock rear sets. The following parts will be used for your new rear set: Gearbox lever with ball joint and counternut.



Rear sets are pre-assembled but all screws are not tightened! Always use locknuts or proper amount of medium thread-locking adhesive (e. g. Loctite 243). All details of assembling are shown on the backside drawing. All parts are welded into their bags as they belong together.



The original brake light switch has to be replaced by a hydraulic one. It replaces the banjo bolt of the brake hose at the brake cylinder. **This is the highest point in the brake-system, proof proper air free installation! Use only seal rings according to the brake hose manufactures' instructions.**

The tightening torques for connections to the frame refers to the manufacturer's instructions. Use the following torques for all the other screw connections:

M5	=	6Nm	=	4.43lbf ft
M6	=	10Nm	=	7.38lbf ft
M8	=	20Nm	=	14.75lbf ft
M10x1,25	=	30Nm	=	22.13lbf ft



Test brake and gear shifting indoor after installing rear set. **If anything is not operating properly or braking efficiency is poor, testing on the road may result in death or serious injury!**

Maintenance:



Periodically proof all functions during service intervals. Use **particle free (no MoS₂)** lithium or barium soap grease to maintain lever bushings.

Important advice: For some positions the reservoir's hose needs to be shortened. Prevent hose from crushing!

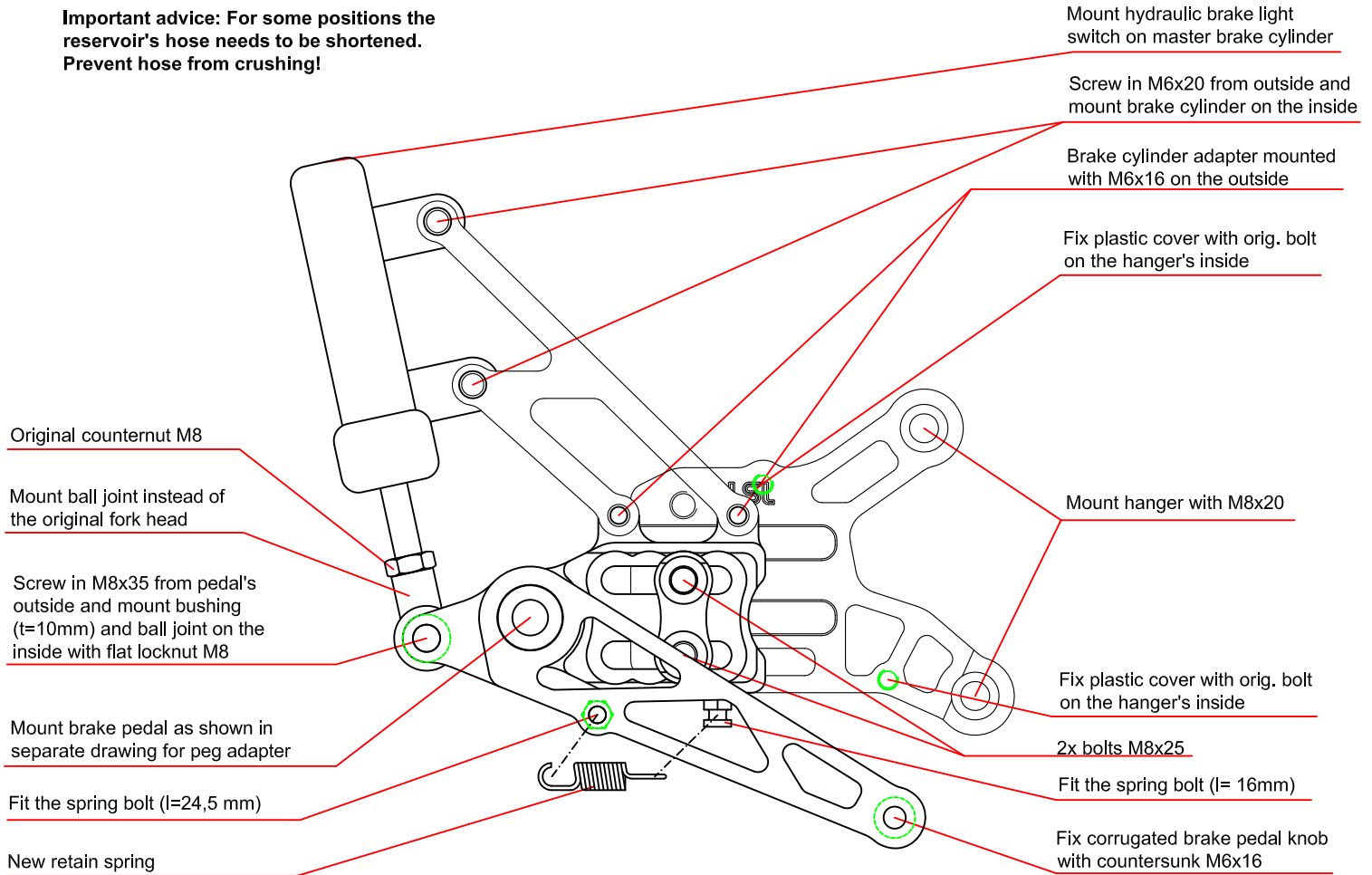

Advice for reversed shifting: Turn the gearbox lever by 180 degrees and support or slightly cut out the fairing

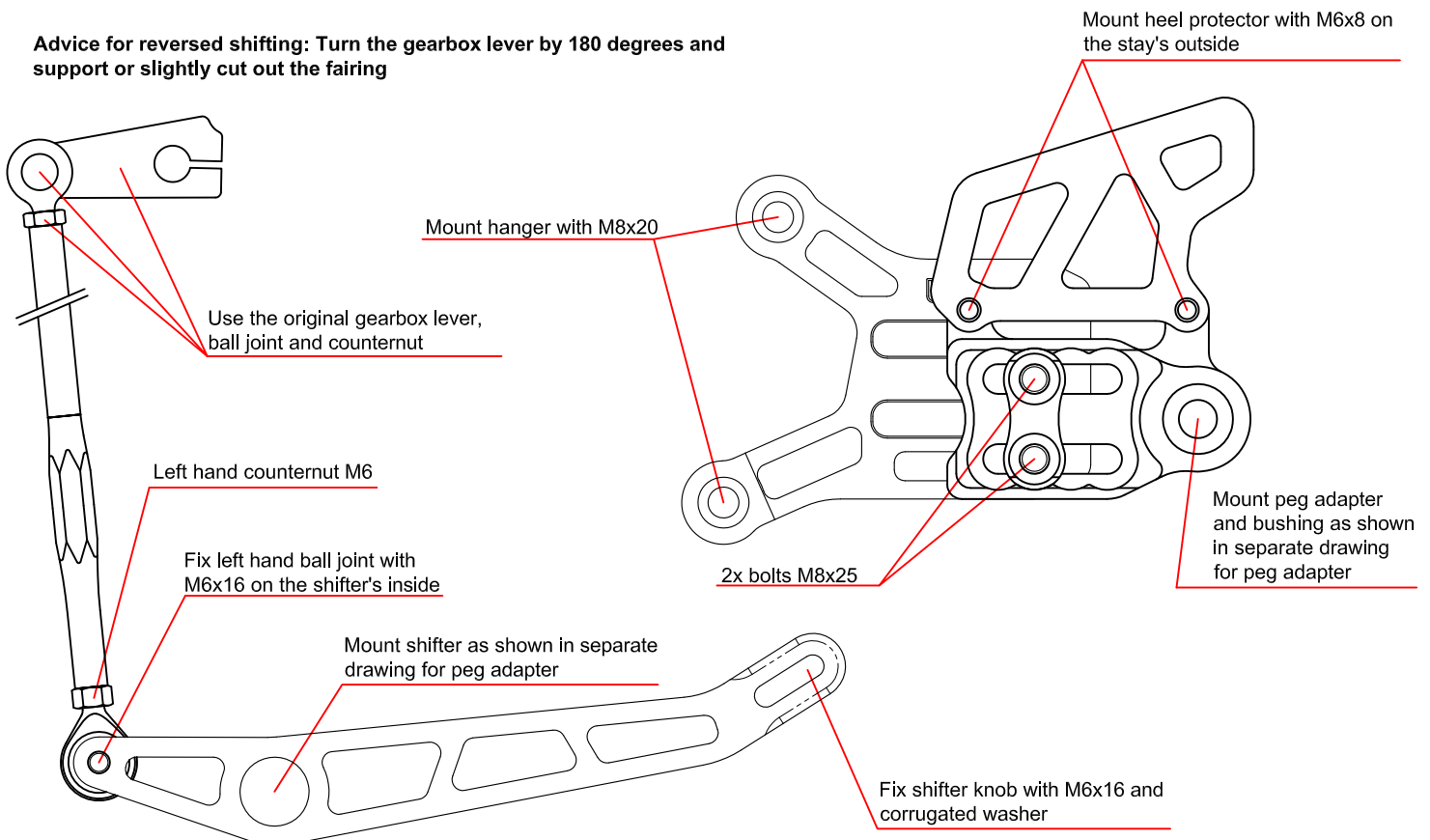

Linke Seite vorne / left front side

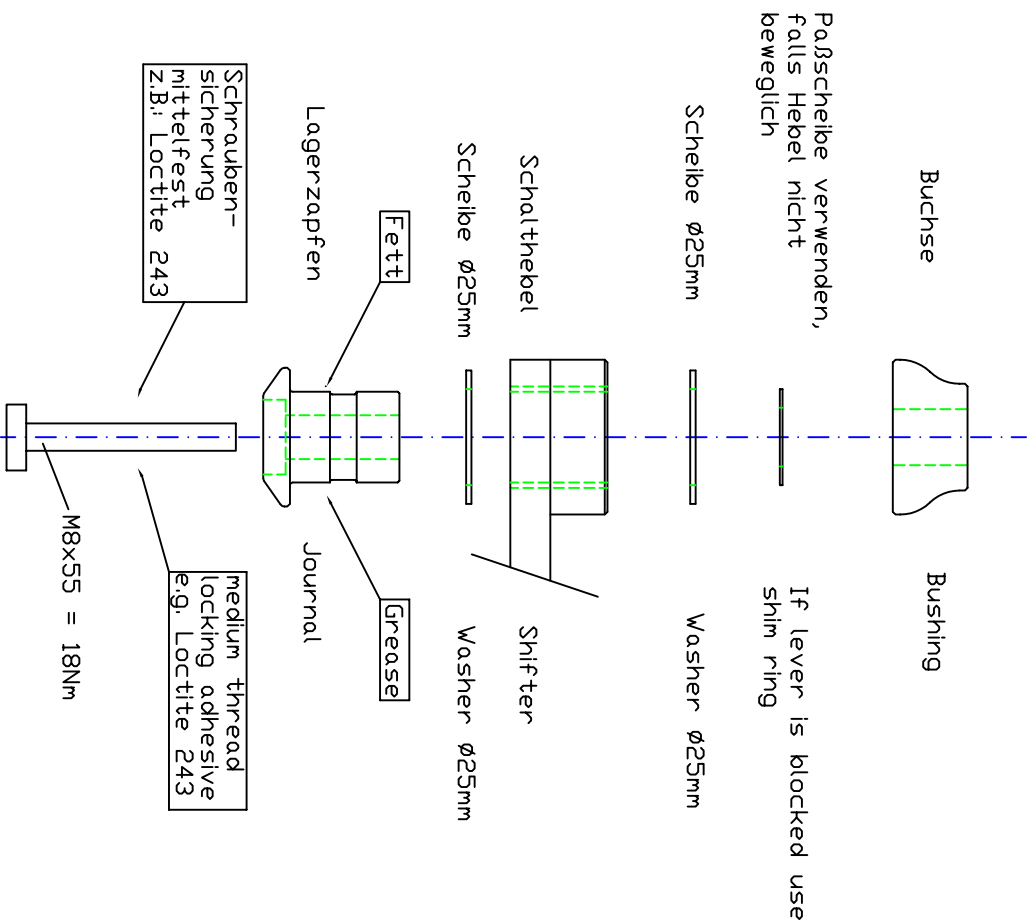

Linke Seite / Left side

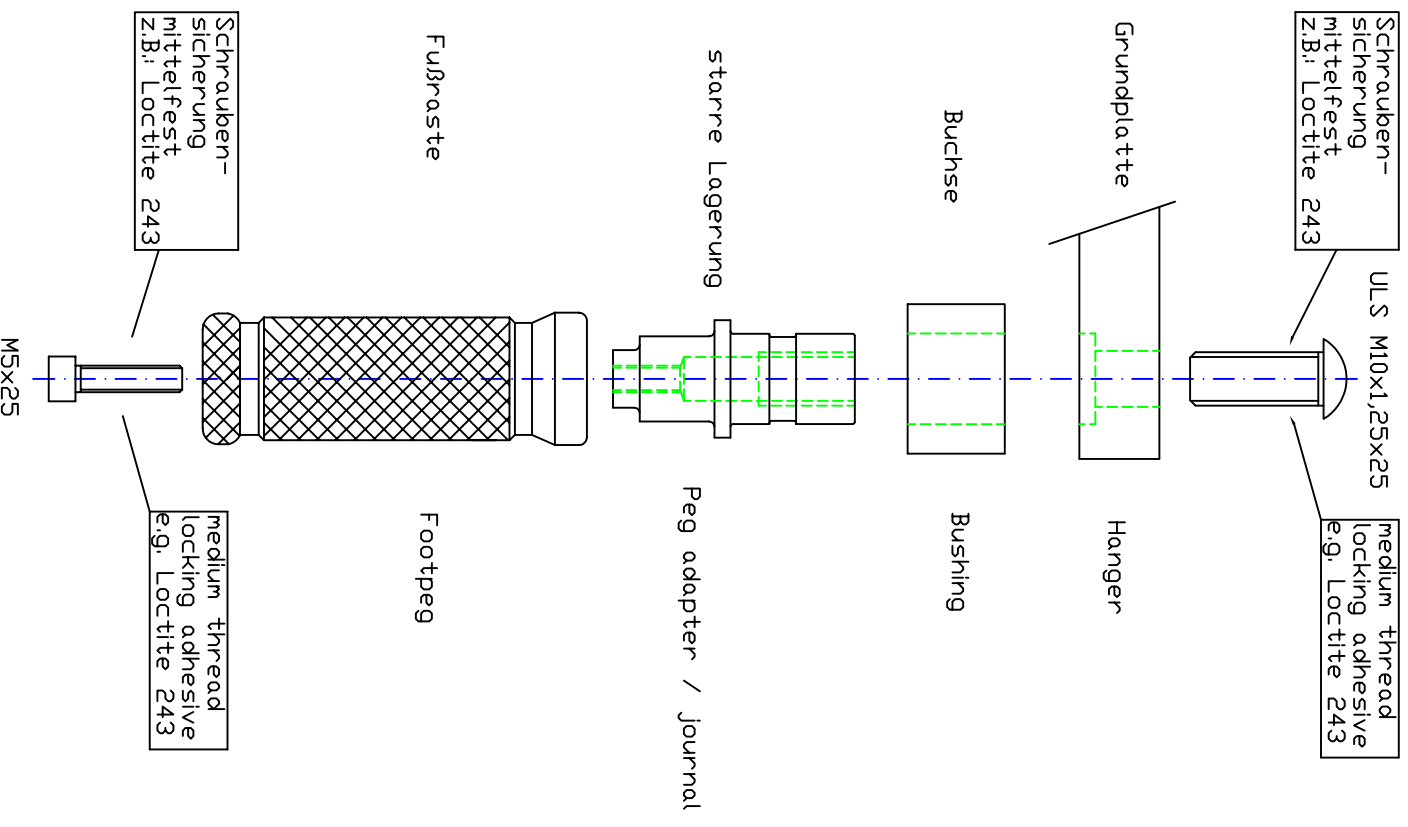

Rechte Seite / Right side

ULS M10x1.25x25

Schrauben-
sicherung
mittelfest
z.B.: Loctite 243

medium thread
locking adhesive
e.g. Loctite 243

Grundplatte

Hanger

ggf. Paßscheibe verwenden
falls Hebel nicht beweglich

If lever is blocked
use shim ring

Scheibe $\varnothing 28\text{mm}$

Washer $\varnothing 28\text{mm}$

Bremshebel

Brake pedal

Scheibe $\varnothing 25\text{mm}$

Washer $\varnothing 25\text{mm}$

starre Lagerung

Peg adapter / journal

Fußbraste

Footpeg

Schrauben-
sicherung
mittelfest
z.B.: Loctite 243

medium thread
locking adhesive
e.g. Loctite 243

M5x25

