



# Fitting Instruction

Article-No. : **118S094**  
Product : **Adjustable Rear Set 2-Slide**  
Manufacturer : **Suzuki**  
Model : **GSX-R 1000 '03 – '04**

## Important:

Read this instruction manual carefully and mind all warnings and tips. You should do this work only if you're qualified; otherwise we recommend this mounting to be done by a qualified workshop. Improperly mounting of this kit can reduce the driveability of the motorcycle and may be a risk to your health and life.

Special works are marked with the following signs. Please take special care on these works.



**Warning! Important mounting instruction. It shows risks to your life and health.**



**Tips for mounting and maintenance or to avoid damage.**

## Fitting:

Remove stock rear sets. The following parts will be used for your new rear set: right heel protector and screws for mounting the brake cylinder



**Rear sets are premount but all screws are not tightened!** Always use locknuts or proper amount of medium thread-locking adhesive (i.e. Loctite 243). All details of assembling are shown on the backside drawing. All parts are welded into their bags as they belong together.



Replace the original brake light switch by a hydraulic one. It replaces the banjo bolt of the brake hose at the brake cylinder. **This is the highest point in the brake-system, proof proper air free installation!**

The tightening torques for connections to the frame refers to the manufacturers' instructions. Use the following torques for all the other screwing:

<b>M5</b>	<b>=</b>	<b>5 - 6Nm</b>
<b>M6</b>	<b>=</b>	<b>9 - 10Nm</b>
<b>M8</b>	<b>=</b>	<b>18 - 22Nm</b>
<b>M10</b>	<b>=</b>	<b>30 - 35Nm</b>



After installing rear set **test brake and gear shifting at low speed. If anything is not operating properly or braking efficiency is poor, testing at high speeds may result in death or serious injury!**

## Maintenance:



Periodically proof all functions during service intervals. Use **particle free (no MoS<sub>2</sub>)** Lithium-/Bariumgrease on soap base to maintain lever bushings.

orig. nut

mount ball joint with screw  
M8x30, bushing  $\varnothing 15 \times 6 \text{mm}$  and  
flat nut M8sl

read fitting instruction/drawing

mount the bolt of the brake lever  
spring from behind

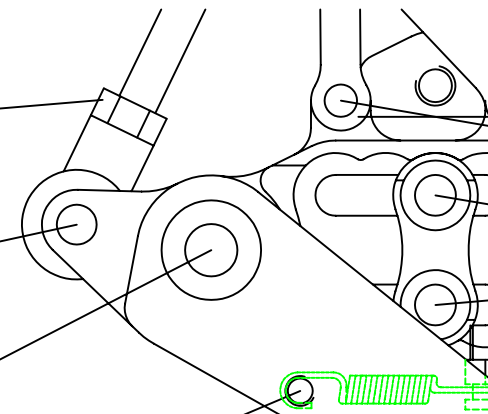

mount the base  
plate with screws  
M8x20 at the frame

mount the lever pin with flat head  
screw M6x16 and corrugated washer

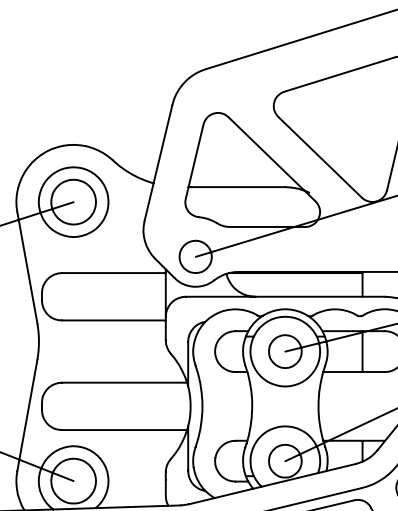

Schrauben-  
sicherung  
mittelfest  
z.B.: Loctite 243

medium thread  
locking adhesive  
f.e. loctite 243

ULS M10x1.25x25

ULS M10x1.25x25

Grundplatte

Stay

ggf. Paßscheibe verwenden  
falls Hebel nicht beweglich

If lever is blocked use  
shim ring

Scheibe  $\varnothing 28\text{mm}$

Washer  $\varnothing 28\text{mm}$

Brems/ Schalthebel

Brake pedal/ Shifter

Scheibe  $\varnothing 25\text{mm}$

Washer  $\varnothing 25\text{mm}$

Fett

Grease

starre Lagerung

M5x20

