



Fitting Instruction

Article-No. : 118K084
Product : **Adjustable Rear Set**
Manufacturer : **Kawasaki**
Model : **ZX-6 R/RR 1998 – 2002**
ZX-9 R 1998 - 2003

Important:

Read this instruction manual carefully and mind all warnings and tips. You should do this work only if you're qualified; otherwise we recommend this mounting to be done by a qualified workshop. Improperly mounting of this kit can reduce the driveability of the motorcycle and may be a risk to your health and life.

Special works are marked with the following signs. Please take special care on these works.



Warning! Important mounting instruction. It shows risks to your life and health.



Tips for mounting and maintenance or to avoid damage.

Fitting:

Remove stock rear sets. The following parts will be used for your new rear set: screws to fix the stay and the gearbox lever with ball joint



Rear sets are pre-assembled but all screws are not tightened! Always use locknuts or proper amount of medium thread-locking adhesive (e. g. Loctite 243). All details of assembling are shown on the backside drawing. All parts are welded into their bags as they belong together.



The original brake light switch has to be replaced by a hydraulic one. It replaces the banjo bolt of the brake hose at the brake cylinder. **This is the highest point in the brake-system, proof proper air free installation!**

The tightening torques for connections to the frame refers to the manufacturers' instructions. Use the following torques for all the other screwing:

| | | | | |
|-----------------|----------|-------------|----------|--------------------|
| M5 | = | 6Nm | = | 4.43lbf ft |
| M6 | = | 10Nm | = | 7.38lbf ft |
| M8 | = | 20Nm | = | 14.75lbf ft |
| M10x1,25 | = | 30Nm | = | 22.13lbf ft |



After installing rear set **test brake and gear shifting at low speed. If anything is not operating properly or braking efficiency is poor, testing at high speeds may result in death or serious injury!**

Maintenance:



Periodically proof all functions during service intervals. Use **particle free (no MoS₂)** lithium or barium soap grease to maintain lever bushings.

Master brake cylinder

Screw in M8x20 with bushing (t=8mm) from behind and mount brake cylinder on the inside

Original counter nut M8

Mount ball joint instead of the original fork head on the push rod. To reach a deep lever position it may be necessary to shorten the push rod

Screw in M8x35 from lever outside and mount bushing (t=10mm) and ball joint on the inside with flat locknut M8

Mount brake lever as shown in separate drawing for peg adapter

2x screws M8x25

Fit the spring-bracket bolt (l=24,5 mm)

Fit the spring-bracket bolt (l= 16mm)

Mount hydraulic brake light switch on master brake cylinder

Brake cylinder adapter

Brake cylinder adapter mounted with M6x16 on the outside

Stay

Mount stay with original screws

New retain spring

Brake Lever

Fix brake lever knob with countersunk M6x16

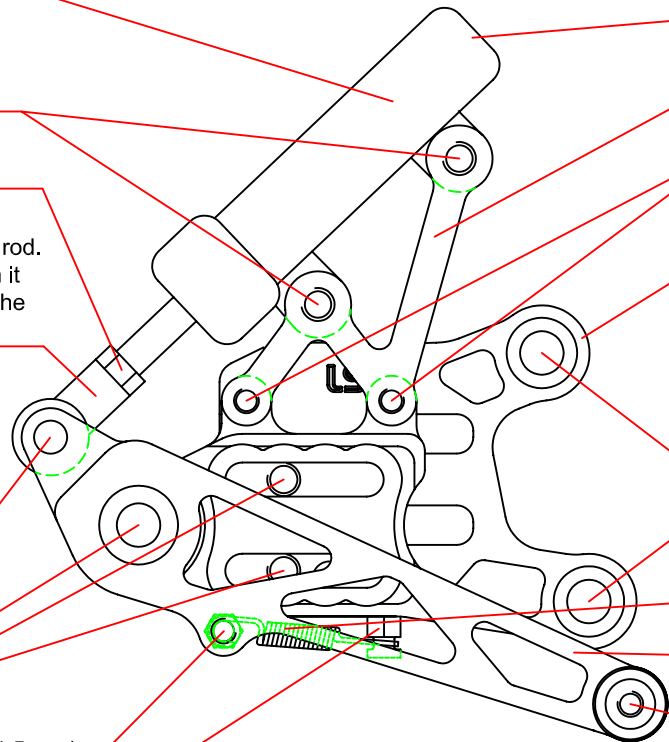

Mount the heel protector with M6x8 on the stays outside

2x screws M8x25

Mount gearshift lever as shown in separate drawing for peg adapter

Fix the ball joint with M6x20 and spacer (t=3mm) on the inside of gearshift lever

Ball joint M6 with counter nut

Mount stay with original screws

Stay

Gearshift lever

Fix gearshift lever knob with M6x16 and corrugated washer

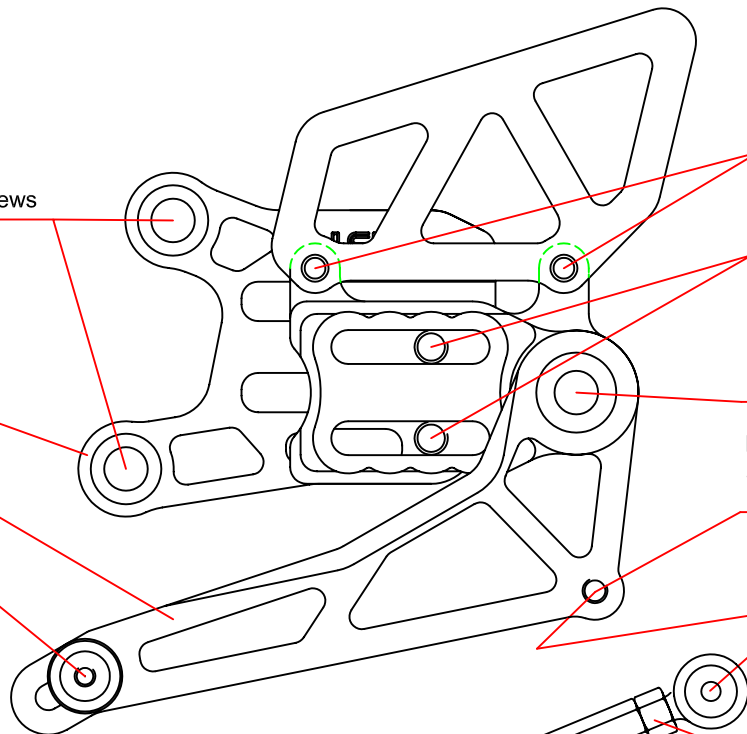

Screw left-hand thread bolt M6x40 into the original ball joint and fix it with Loctite, then mount and adjust gearshift rod with original counter nut

Use the attached spacers 2 x 20mm and 1 x 10mm for your individual position

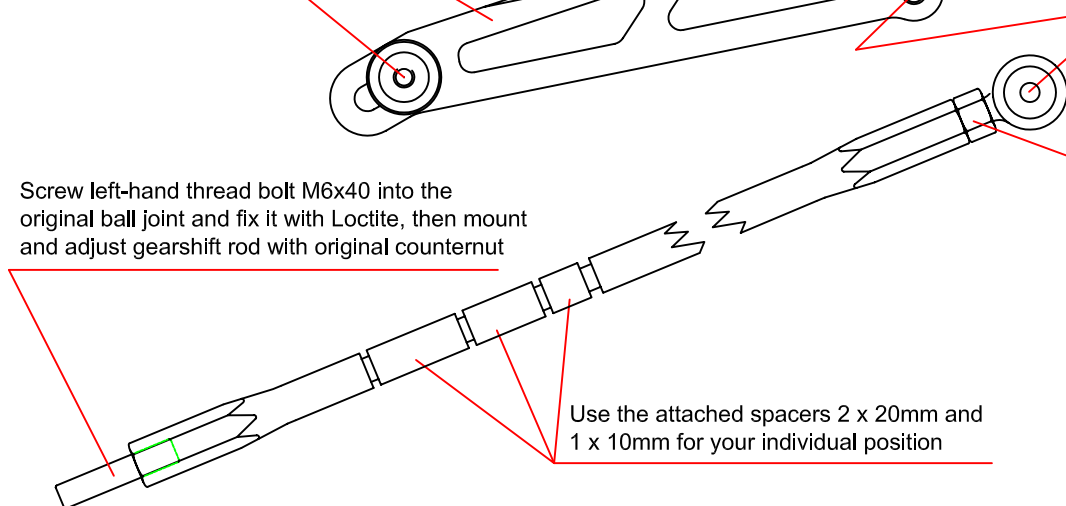

ULS M10x1.25x25

Schrauben-
sicherung
mittelfest
z.B.: Loctite 243

medium thread
locking adhesive
e.g. Loctite 243

Grundplatte

Stay

ggf. Paßscheibe verwenden
falls Hebel nicht beweglich

If lever is blocked use
shim ring

Scheibe Ø28mm

Washer Ø28mm

Brems/ Schalthebel

Brake pedal/ Shifter

Scheibe Ø25mm

Washer Ø25mm

Fett

Grease

starre Lagerung

Peg adapter

M5x20

