

Kawasaki Z750 '04 - '06

Important! If you are not a trained motorcycle mechanic stop now. Ask a local motorcycle shop to do the work for you.

Please make sure that the steering damper is not used as a steering stop!

Steering damper : 120 mm stroke

Start with lowest damping for first ride and check all connections!

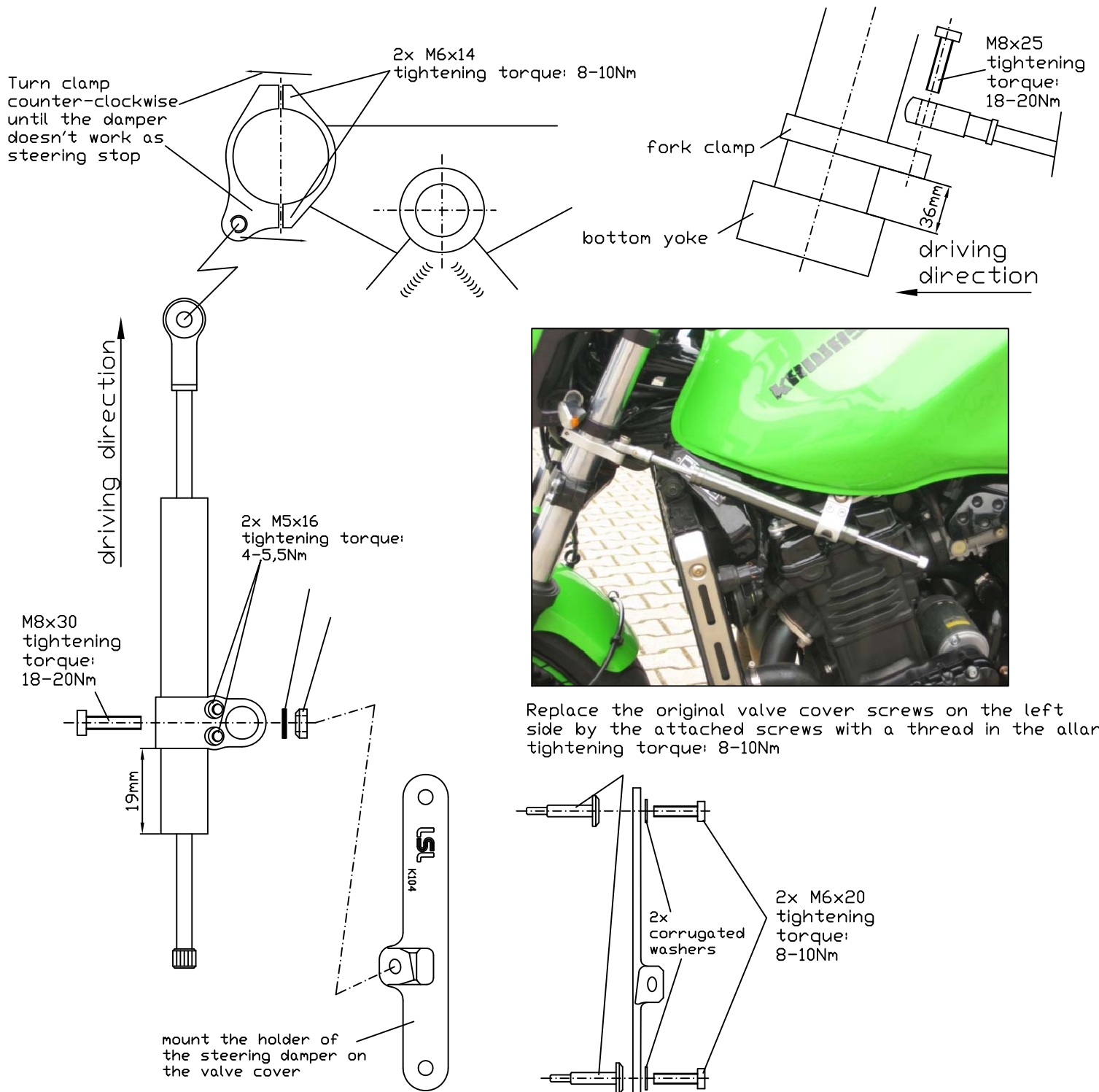

Replace the original valve cover screws on the left side by the attached screws with a thread in the allen. tightening torque: 8-10Nm

Please take note of the general instruction as printed on the other side of this paper about the fitting, use and adjustment of the LSL-steering dampers.

General fitting instructions for steering dampers

Important! If you are not a trained motorcycle mechanic stop now. Ask a local motorcycle shop to do the work for you.

- 1.) Always refer to the specific fitting instructions according to your vehicle model!
- 2.) The steering damper should never limit the steering angle under any circumstances by its own limited damping stroke. Steering angle must only be limited by the manufacturers intended lock stop. If limited by the steering damper the unit will be damaged and steering performance will be poor.
Under certain circumstances this might cause the rider to loose control of the bike, which may result in serious injury or death!
Also make sure that clearance is given to damper rod at any steering angle.
- 3.) Damping force and dimensions of mounting brackets are designed to provide complete control and smooth steering performance under any circumstances. But be aware of that by rising distance between damper mount and steering pivot the damping force will rise disproportionate. On unprofessional installation and highest damping adjustment this may cause poor steering performance or high steering forces.
This might cause the rider to loose control of the bike, which may result in serious injury or death. Always start with lowest damping rate for first ride!
- 4.) Always use locknuts or proper amount of medium thread-locking adhesive (e.g. Loctite 243).
- 5.) Check fork lock for proper performance and easy accessibility.
- 6.) Always check local laws and manufacturers warranty conditions for using aftermarket parts on your bike.
- 7.) LSL-steering dampers are only designed to work with LSL-mounting kits. By using other brands we will not cover warranty for damper or mounting kits and performance might not be impeccable.

Ride save and have fun!



LSL-Motorradtechnik GmbH • D-47809 Krefeld

www.lsl-motorradtechnik.de