

Accessory

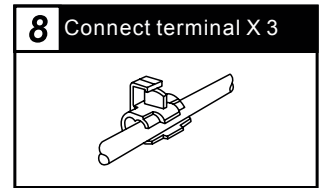

NOTE Please contact the local distributor if the items you open are not the same, with the above-listed one.

Wiring installation instructions

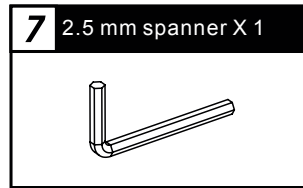
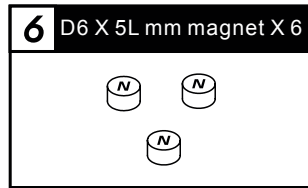
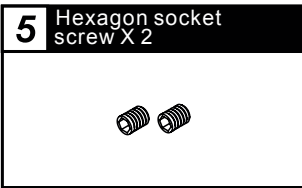
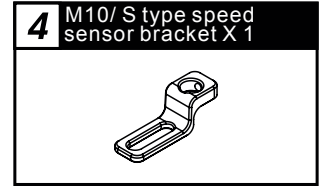
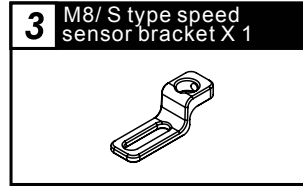
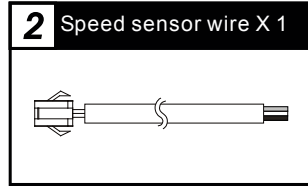
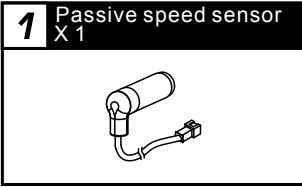
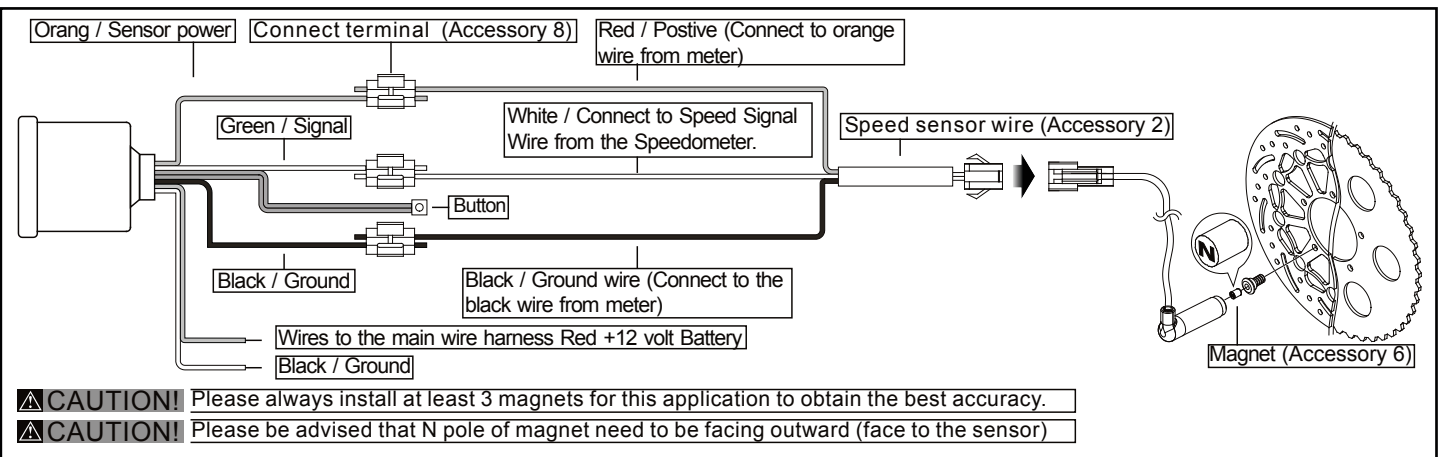

Installation instructions

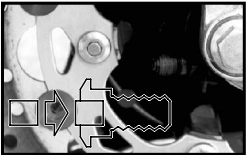

Put the magnet into the brake disc screw hole.



Install the s type sensor bracket.

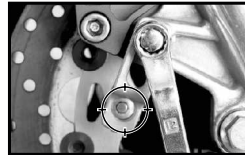

Adjust the sensor bracket position to make sure that the sensor could face the magnet to prevent bad speed signal or no signal!

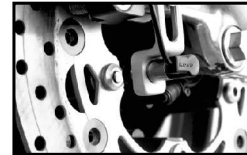

Install the speed sensor on the bracket.

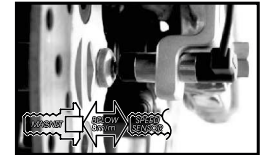

Adjust the distance between sensor and magnet. We suggest you to make sure the distance is under 8mm for catching good speed signal.