

Gepäckbrücke
TRIUMPH Tiger 1050

Artikel-Nr.:
4006.001.201 schwarz

KRAUSER[®]
MOTORRADGEPÄCKSYSTEME ■ BIKE BAGS

Montage

St.	Bestellnr.	Bezeichnung
1	799.997	Alu-Rack
1	799.904	Abdeckplatte für Rack
1	708.214	Rohradapter links
1	708.215	Rohradapter rechts
2	150.938	Linsenkopfschraube M8 x 20
4	150.763	Inbusschrauben M6 x 20
4	150.799	Selbtsichernde Mutter M6
4	150.809	U-Scheibe ø6,4
2	150.810	U-Scheibe ø8,4
4	150.164	Viereck-Scheiben 20 x 20 x ø6,4
2	150.818	Distanz ø18 x ø9 x 7mm
1	330.300	Schriftzug „KRAUSER“



Anzugsmomente des Motorradherstellers beachten!
Nach der Montage alle Verschraubungen auf festen Sitz kontrollieren!
Bitte beachten Sie unsere beigefügten Serviceinformationen.

Weiteres Zubehör:

4006.001.111 Kofferträger schwarz "Lock it System" (abnehmbar)
3006.001.101 Motorschutzbügel schwarz
3006.001.501 Hauptständer schwarz



Krauser GmbH
An der Steinmauer 6

D-66955 Pirmasens

Tel.: 06331 - 1453 - 250
Fax: 06331 - 1453 - 260
eMail: vertrieb@krauser.de
www.krauser.de

Gepäckbrücke
TRIUMPH Tiger 1050

Artikel-Nr.:
4006.001.201 schwarz

KRAUSER[®]

MOTORRADGEPÄCKSYSTEME ■ BIKE BAGS

Montage

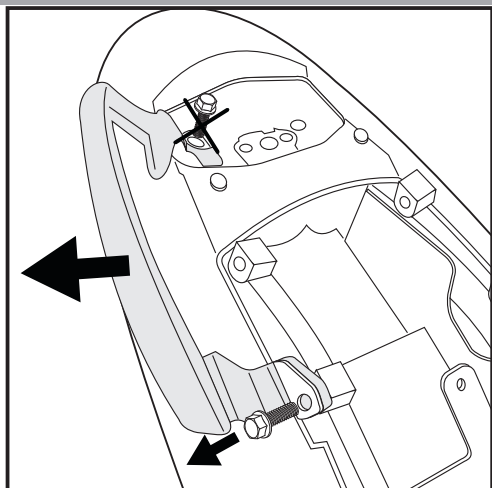

1

Vorbereitende Arbeiten:

Die Blinker verbleiben in der Originalposition.
Sitzbank abnehmen.
Soziushaltegriffe demontieren; diese entfallen.

Tipp:

Schrauben sie alle Teile an und lassen sie die zugänglichen Schrauben etwas locker. Nachdem alles montiert ist, werden alle Schrauben auf das entsprechende Anzugsmoment angezogen. Dadurch wird sichergestellt, dass das Produkt spannungsfrei angebaut ist.

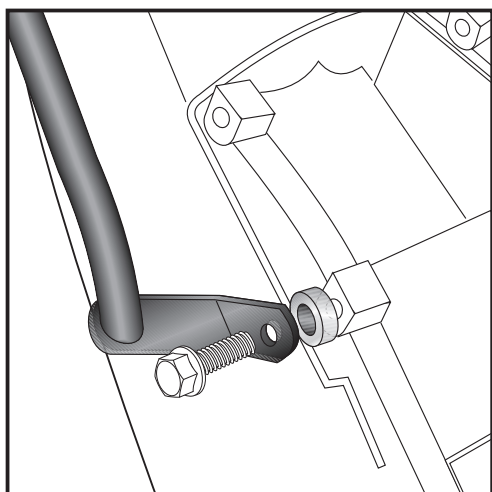

2

Montage der Rohradapter vorne links und rechts:

Diese erfolgt an den freien Gewindebohrungen der Soziushaltegriffe. Rohradapter positionieren, die Distanzen $\varnothing 18 \times \varnothing 9 \times 7$ zwischen Rohradapter und Motorrad schieben und mit Original-Schrauben befestigen.

Achtung: Bei montierten Kofferträgern entfällt die Distanz !

2x

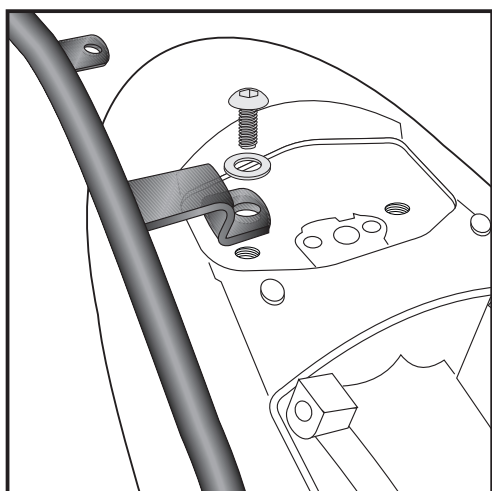

3

Montage der Rohradapter hinten links und rechts:

Mit den Linsenkopfschrauben M8x20 und U-Scheiben $\varnothing 8,4$ an den freien Gewindebohrungen.

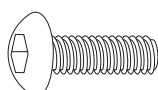

je 2x



Gepäckbrücke
TRIUMPH Tiger 1050

Artikel-Nr.:
4006.001.201 schwarz

KRAUSER[®]

MOTORRADGEPÄCKSYSTEME ■ BIKE BAGS

Montage

Montage des Alu-Rack:

Das Alu-Rack wird mit den Inbus-schrauben M6 x 20, Viereck-Scheiben 20 x 20 x ø6,4, U-Scheiben ø6,4 und selbstsichernden Muttern M6 an den Laschen der Rohradapter verschraubt.

Anschließend die Kunststoffabdeckung des Alu-Racks montieren.

4

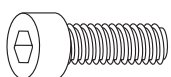
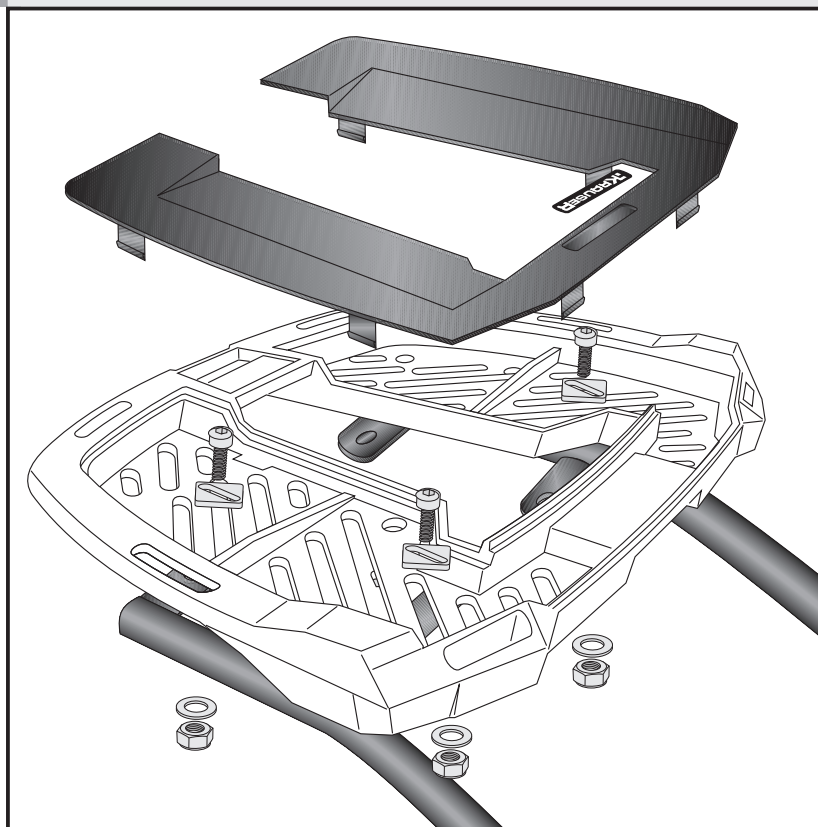

je 4x

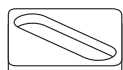

Rear carrier
TRIUMPH Tiger 1050

Item - No.:
4006.001.201 black

KRAUSER[®]
MOTORRADGEPÄCKSYSTEME ■ BIKE BAGS

Assembling instructions

The kit includes the following parts:

Quant	item no.	description
1	799.997	alu-rack
1	799.904	plastic cover for rack
1	708.214	rear rack holder left
1	708.215	rear rack holder right
2	150.938	fillister head screw M8 x 20
4	150.763	allen screw M6 x 20
4	150.799	self-lock nut M6
4	150.809	washer ø6,4
2	150.810	washer ø8,4
4	150.164	special washer 20 x 20 x ø6,4
2	150.818	spacer ø18 x ø9 x 7
1	330.300	Emblem „KRAUSER“



Control all screw connections after the assembling for tightness!
Please notice our enclosed service information.

Also available:

Item-no.: 4006.001.111

Side carrier, Lock it-System (demountable), black

Item-no.: 3006.001.101

Engine guard, black

Item-no.: 3006.001.501

Centre stand, black



Krauser GmbH
An der Steinmauer 6
D-66955 Pirmasens
Germany

Tel.: +49 6331 - 1453 - 250
Fax: +49 6331 - 1453 - 260
eMail: vertrieb@krauser.de
www.krauser.de

Assembling instructions

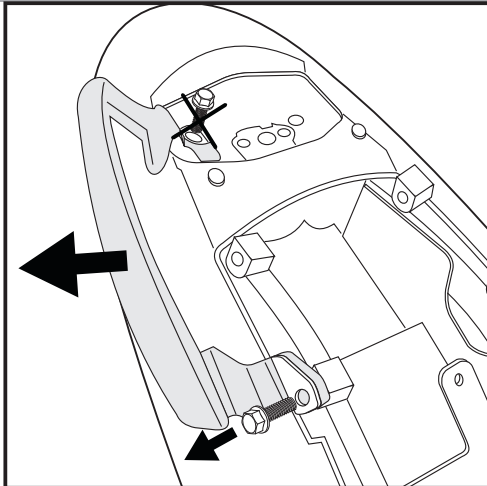

1

Preparing:
Unmount seat and handrails.

Tip:

Fit all parts and screw on not too strong.
After mounting all parts, the screws should be tightened to the torque specified.
This guarantees, that the kit is mounted without tension.

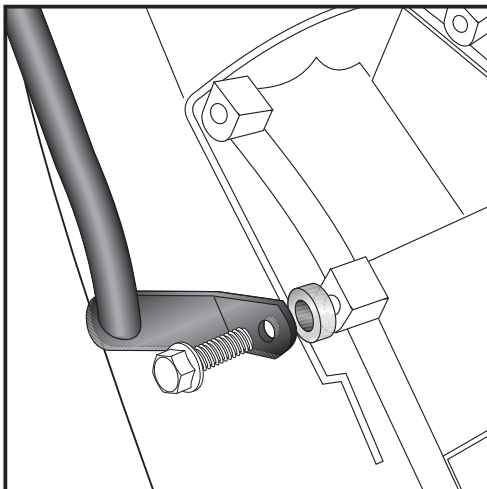

2

Fastening of the rear rack front:
Sandwich spacer $\varnothing 18 \times \varnothing 9 \times 7$ between rear rack and motorbike and fix it with original screws.

Notice:
Spacer is not used if assembling with the side carrier !

2x 

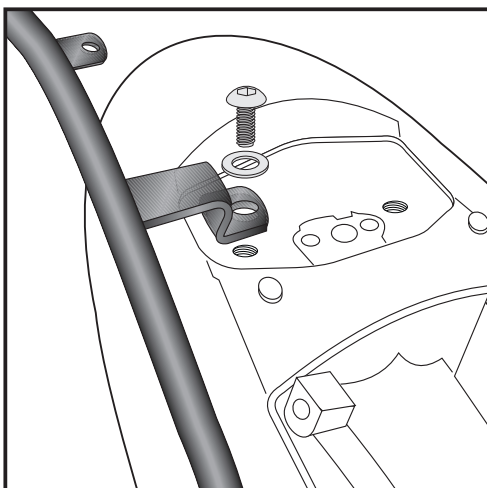

3

Fastening of the rear rack back:
with filister head screw M 8 x 20 and washers $\varnothing 8,4$.

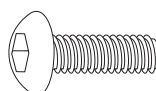

each 2x



Rear carrier
TRIUMPH Tiger 1050

Item - No.:
4006.001.201 black

KRAUSER[®]
MOTORRADGEPÄCKSYSTEME ■ BIKE BAGS

Assembling instructions

Fastening of the alu-rack:
with allen screws M6 x 20, special washer
20 x 20 x ø6,4, washers ø6,4 and self-
lock nuts M6.

Mount the plastic cover.

4

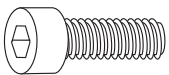
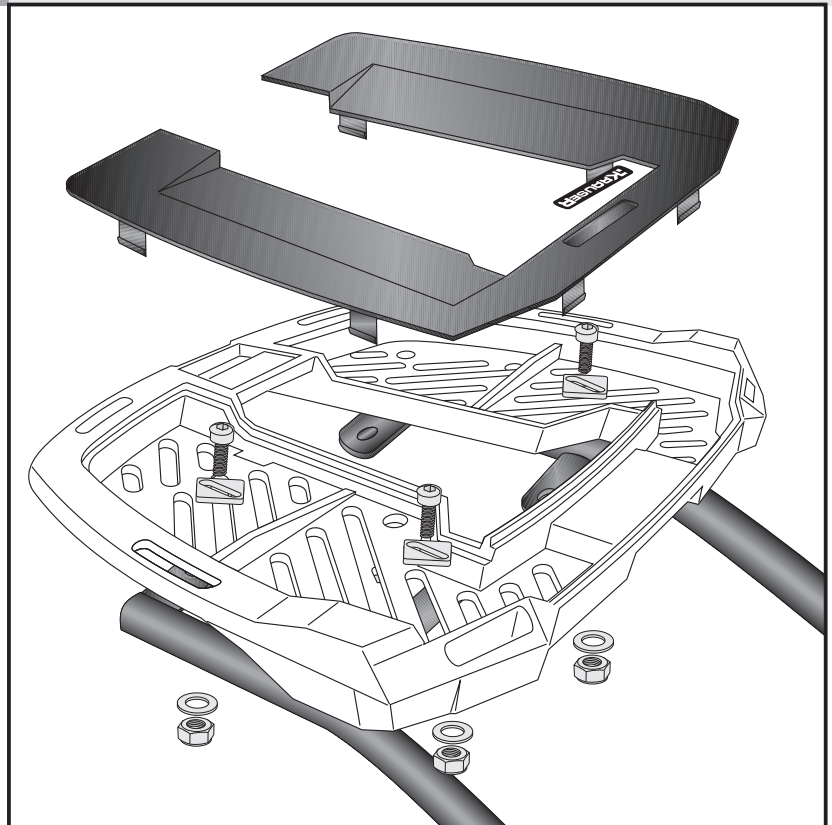

each
4x

