

MONORACK SPECIFICO - SPECIFIC MONORACK
MONORACK SPECIFIQUE - SPEZIFISCHES MONORACK - MONORACK ESPECÍFICO

HONDA VFR 800 '02/'05 VTEC

ISTRUZIONI DI MONTAGGIO - MOUNTING INSTRUCTIONS
INSTRUCTIONS DE MONTAGE - BAUANLEITUNG - INSTRUCCIONES DE MONTAJE

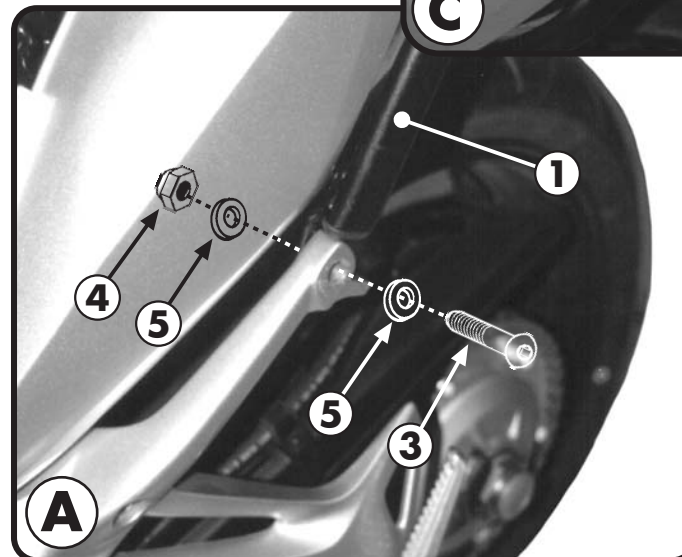
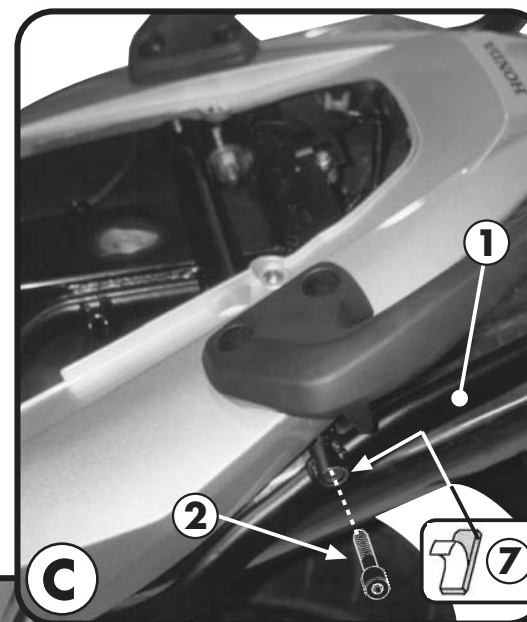
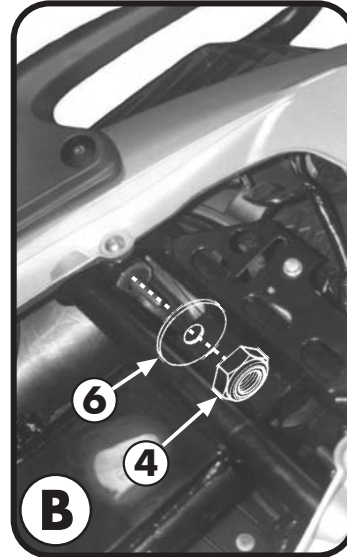
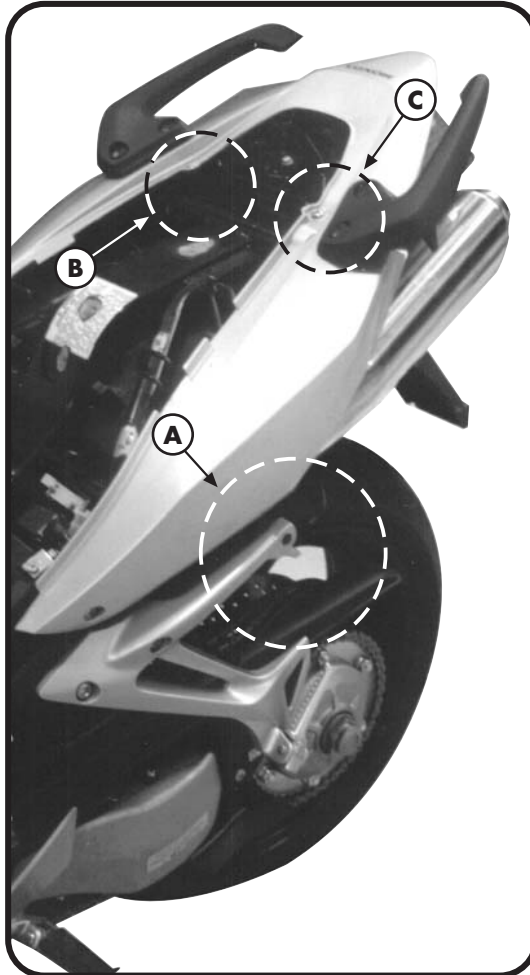
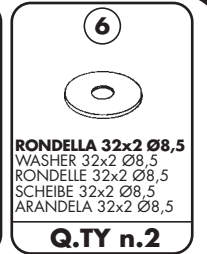
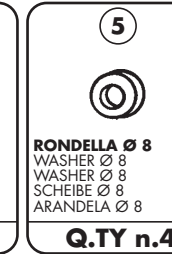
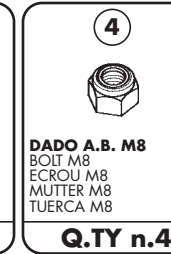
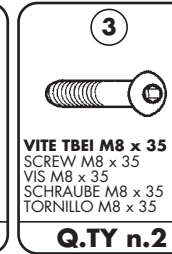
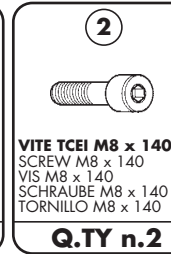
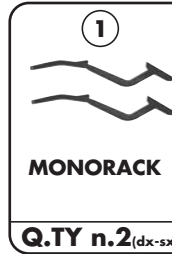

ATTENZIONE
PESO MASSIMO SOPPORTABILE
DAL PORTAPACCO 10Kg.

WARNING
MAX. LOADING OF THE CARRIER
10Kg.(21lbs)

ATTENTION
CHARGE MAXIMALE 10Kg.

ACHTUNG
MAXIMALE BELASTUNG DES
TRAGERS 10Kg.

¡ATENCIÓN!
CARGA MAXIMA AUTORIZADA
10Kg.

MONORACK SPECIFICO - SPECIFIC MONORACK
 MONORACK SPECIFIQUE - SPEZIFISCHES MONORACK - MONORACK ESPECÍFICO

HONDA VFR 800 '02/'05

VTEC

ISTRUZIONI DI MONTAGGIO - MOUNTING INSTRUCTIONS
 INSTRUCTIONS DE MONTAGE - BAUANLEITUNG - INSTRUCCIONES DE MONTAJE

9



SUPPORTO
 SUPPORT
 SUPPORT
 HALTERUNG
 SOPORTE

Q.TY n.2(Dx-Sx)

10

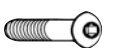

VITE TBEI M8x50mm
 SCREW M8x50mm
 VIS M8x50mm
 SCHRAUBE M8x50mm
 TORNILLO M8x50mm

Q.TY n.4

11



DISTANZIALE Ø18x15mm
 Foro Ø8,5mm, V544
 SPACER
 ENTRETÔISE
 DISTANZSTÜCK
 DISTANCIADOR

Q.TY n.4

12



RONDELLA Ø8x14mm
 WASHER Ø8x14mm
 RONDELLE Ø8x14mm
 SCHEIBE Ø8x14mm
 ARANDELA Ø8x14mm

Q.TY n.4

13



VITE TCEI M6x25mm
 SCREW M6x25mm
 VIS M6x25mm
 SCHRAUBE M6x25mm
 TORNILLO M6x25mm

Q.TY n.2

14



RONDELLA Ø6mm
 WASHER Ø6mm
 RONDELLE Ø6mm
 SCHEIBE Ø6mm
 ARANDELA Ø6mm

Q.TY n.2

15



RONDELLA Ø6x18mm
 WASHER Ø6x18mm
 RONDELLE Ø6x18mm
 SCHEIBE Ø6x18mm
 ARANDELA Ø6x18mm

Q.TY n.2

16



DADO A.B. M6
 BOLT M6
 ECROU M6
 MUTTER M6
 TUERCA M6

Q.TY n.2

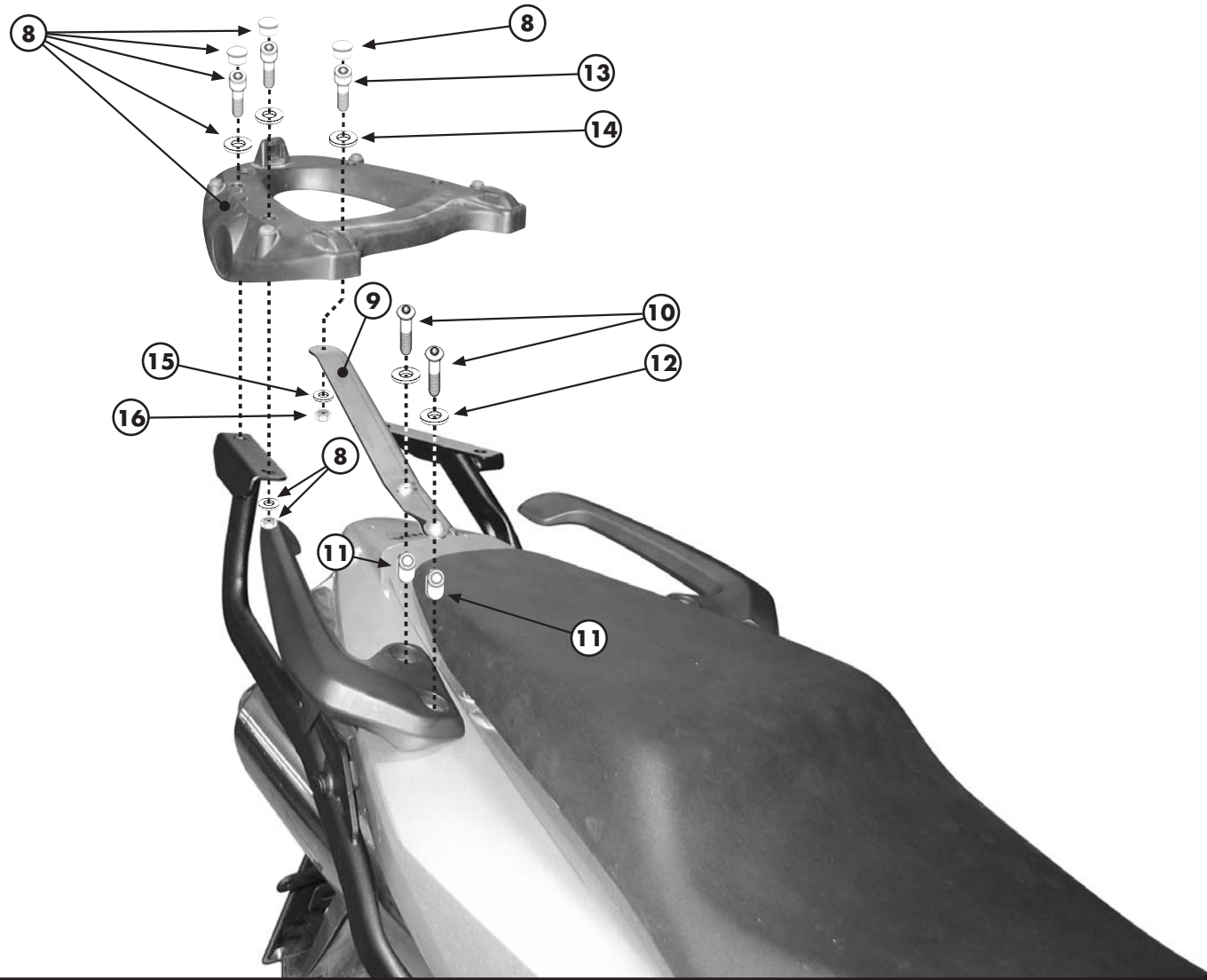

D

MONORACK SPECIFICO - SPECIFIC MONORACK
MONORACK SPECIFIQUE - SPEZIFISCHES MONORACK - MONORACK ESPECÍFICO

HONDA VFR 800 '02/'05
VTEC

ISTRUZIONI DI MONTAGGIO - MOUNTING INSTRUCTIONS
 INSTRUCCIONES DE MONTAJE - BAUANLEITUNG - INSTRUCCIONES DE MONTAJE

I ISTRUZIONI DI MONTAGGIO

1. ESEGUIRE IL MONTAGGIO DEL MONORACK COME INDICATO NELLE FOTOGRAFIE DALLA A ALLA C, SENZA SERRARE COMPLETAMENTE LE VITI; FARE ATTENZIONE A POSIZIONARE CORRETTAMENTE LA MOUSSE PROTETTIVA COME INDICATO IN FOTOGRAFIA C;
2. MONTARE, COME ILLUSTRATO IN FOTOGRAFIA D, IL SUPPORTO DI RINFORZO N°9 DESTRO E SINISTRO;
3. MONTARE LA PIASTRA DI FISSAGGIO DEL BAULETTO (NON INCLUSA), FOTOGRAFIA D;
4. INIZIARE IL SERRAGGIO DELLE VITI PARTENDO DALLA N°5 E LE N°2;
5. ULTIMARE IL MONTAGGIO SERRANDO BENE TUTTE LE VITI.

GB MOUNTING INSTRUCTIONS

1. MOUNT THE MONORACK AS SHOWN IN THE PICTURES A TO C, WITHOUT COMPLETELY TIGHTENING THE SCREWS; PAY ATTENTION TO PLACE CORRECTLY THE PROTECTIVE RUBBER PAD AS SHOWN IN PICTURE C;
2. MOUNT THE REINFORCEMENT SUPPORT N° 9, BOTH RIGHT AND LEFT SIDES, AS SHOWN IN PICTURE D;
3. MOUNT THE TOP-CASE PLATE (SOLD SEPARATELY) AS SHOWN IN PICTURE D;
4. TIGHTEN THE SCREWS STARTING FROM THE N° 5 AND THE N° 2;
5. LASTLY CHECK THAT ALL THE SCREWS HAVE BEEN TIGHTENED.

F INSTRUCTIONS DE MONTAGE

1. FAIRE LE MONTAGE DU MONORACK COMME INDIQUE DE LA PHOTO A A LA PHOTO C, SANS COMPLETEMENT SERRER LES VIS; FAIRE ATTENTION A POSITIONNER CORRECTEMENT LA MOUSSE DE PROTECTION COMME INDIQUE SUR LA PHOTO C;
2. MONTER, COMME ILLUSTRÉ SUR LA PHOTO D, LES PATTES DE RENFORT N°9 DROITE ET GAUCHE;
3. MONTER LA PLATINE SUPPORT TOP CASE (NON INCLUSE), PHOTO D;
4. COMMENCER LE SERRAGE DES VIS EN PARTANT DE LA N°5 ET DE LA N°2;
5. FINIR LE MONTAGE EN CONTROLANT LE BON SERRAGE DE TOUTES LES VIS.

D BAUANLEITUNG

1. MONTIEREN SIE DAS MONORACK WIE IM BILD A ZU C BESCHRIEBEN, OHNE DIE SCHRAUBEN FESTZUZIEHEN; PASSEN SIE AUF, DIE SCHUTZGUMMI WIE IM BILD C KORREKT ZU POSITIONIEREN;
2. MONTIEREN SIE DIE VERSTÄRKUNGS-STREBEN NR. 9, RECHTE UND LINKE SEITE, WIE IN BILD D BESCHRIEBEN;
3. MONTIEREN SIE JETZT DIE HALTE-PLATTE FÜR DIE BEFESTIGUNG DES KOFFERS, WIE IM BILD D BESCHRIEBEN;
4. NACH FOLGENDER REIHENFOLGE DIE SCHRAUBEN FESTZIEHEN: ZUERST DIE SCHRAUBEN NR. 5 UND DANN DIE SCHRAUBEN NR. 2
5. ZULETZT ÜBERPRÜFEN SIE, DASS ALLE SCHRAUBEN FESTGEZOGEN WURDEN.

ES

INSTRUCCIONES DE MONTAJE

1. EJECUTAR EL MONTAJE DEL MONORACK COMO INDICAN LAS FOTOS DE A A C, SIN APRETAR LOS TORNILLOS; PRESTAR ATENCIÓN AL COLOCAR LA GOMA PROTECTORA DEL CARENADO COMO INDICA LA FOTO C;
2. MONTAR LOS SOPORTES DE REFUERZO DERECHO E IZQUIERDO N° 9 COMO INDICA LA FOTO D;
3. MONTAR LA PARRILLA DE ANCLAJE DEL TOP CASE (NO INCLUIDA – SE VENDE POR SEPARADO) COMO INDICA LA FOTO D;
4. ¡ATENCIÓN!: EMPEZAR A APRETAR LOS TORNILLOS EMPEZANDO POR LOS N° 5 Y LOS N° 2;
5. TERMINAR EL MNTAJE APRETANDO A FONDO LOS TORNILLOS.