

PIASTRA SPECIFICA - SPECIFIC PLATE  
PLATINE SPECIFIQUE - SPEZIFISCHE PLATTE - PLETINA ESPECÍFICA

# GILERA NEXUS 500 2005

ISTRUZIONI DI MONTAGGIO - MOUNTING INSTRUCTIONS  
INSTRUCTIONS DE MONTAGE - BAUANLEITUNG - INSTRUCCIONES DE MONTAJE



**1**  
**SUPPORTO**  
SUPPORT  
HALTER  
SOPORTES  
**GL825**

**Q.TY n.1**



**2**  
**COMPONENTI ORIGINALI**  
ORIGINAL PARTS  
ORIGINAL BAUTEILE  
PARTIES ORIGINALES  
COMPONENTES ORIGINALES

**Q.TY n.-**

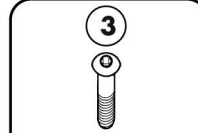

**3**  
**VITE TBEI M8x40mm**  
SCREW M8x40mm  
VIS M8x40mm  
SCHRAUBE M8x40mm  
TORNILLO M8x40mm

**Q.TY n.4**

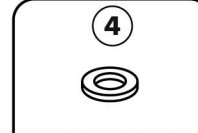

**4**  
**RONDELLA Ø8x14**  
WASHER Ø8x14  
RONDELLE Ø8x14  
SCHEIBE Ø8x14  
ARANDELA Ø8x14

**Q.TY n.4**



**5**  
**DISTANZIALE Ø16x26 foro 8,5**  
SPACER  
ENTRETOISE  
DISTANZSTUECK  
DISTANCIADOR

**Q.TY n.2**



**6**  
**DISTANZIALE Ø16x22 foro 8,5**  
SPACER  
ENTRETOISE  
DISTANZSTUECK  
DISTANCIADOR

**Q.TY n.2**

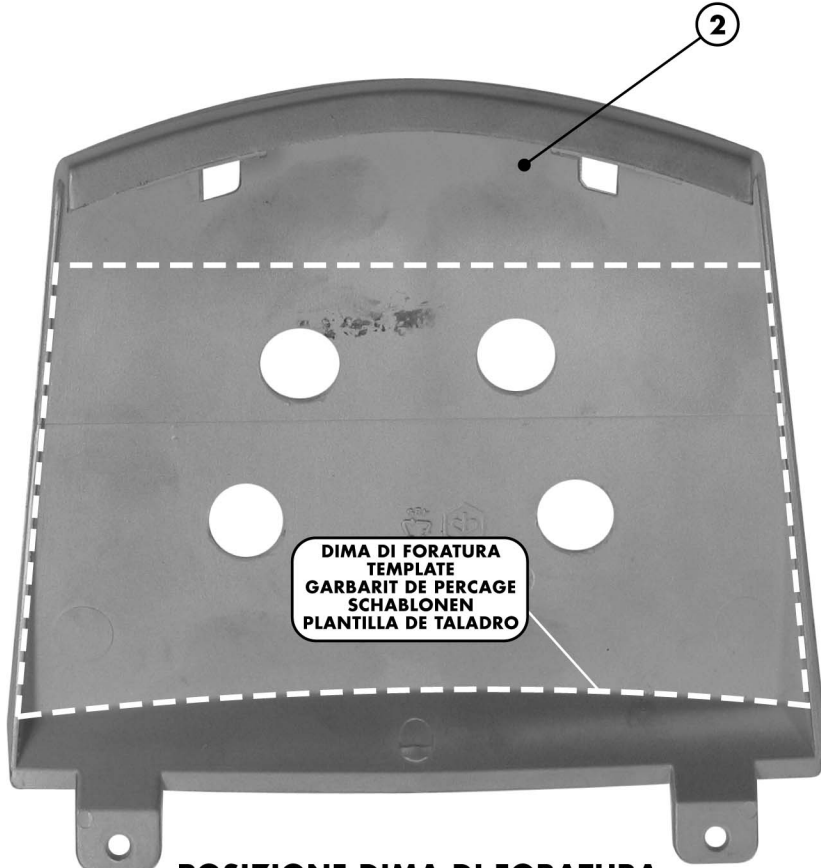

**POSIZIONE DIMA DI FORATURA**  
**POSITION OF THE TEMPLATE**  
**POSITION DU GARBARIT DE PERCAGE**  
**SCHABLONEN POSITION**  
**POSICION PLANTILLA DE TALADRO**

**A**

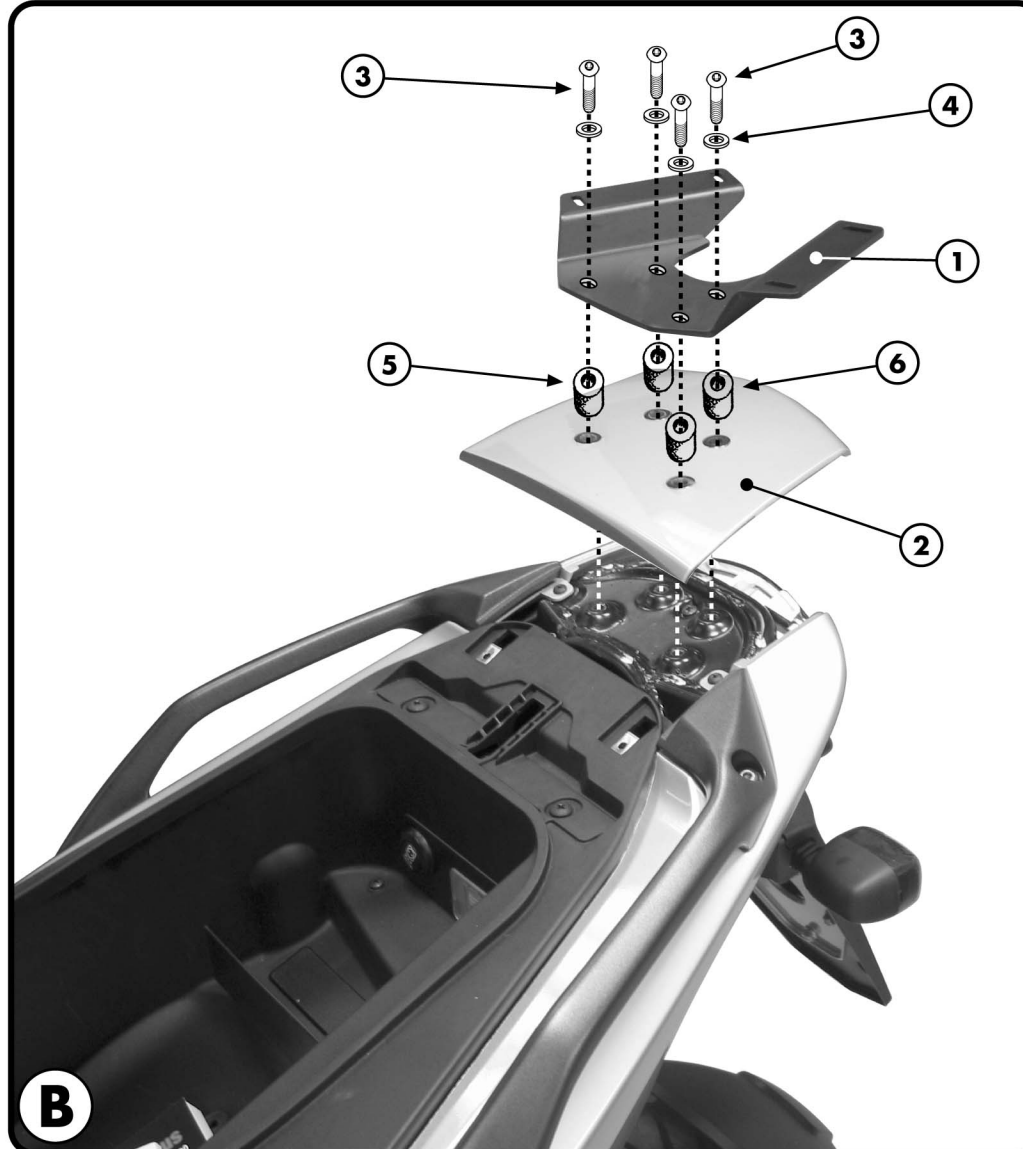

**B**

**7**



**7**  
**RONDELLA Ø6**  
WASHER Ø6  
RONDELLE Ø6  
SCHEIBE Ø6  
ARANDELA Ø6

**Q.TY n.8**

**8**



**8**  
**PIASTRA**  
PLATE  
PLATINE  
PLATTE  
PLETINA  
**Z667M**

**Q.TY n.1**

**9**

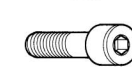

**9**  
**VITE TCEI M6x25mm**  
SCREW M6x25mm  
VIS M6x25mm  
SCHRAUBE M6x25mm  
TORNILLO M6x25mm

**Q.TY n.4**

**10**



**10**  
**COPRIFORO**  
BOLT CAP  
CACHE TROU  
STOPLOCK  
TAPA AGUJERO

**Q.TY n.6**

E682M - K682M

PIASTRA SPECIFICA - SPECIFIC PLATE  
PLATINE SPECIFIQUE - SPEZIFISCHE PLATTE - PLETINA ESPECÍFICA

# GILERA NEXUS 500 2005

ISTRUZIONI DI MONTAGGIO - MOUNTING INSTRUCTIONS  
INSTRUCTIONS DE MONTAGE - BAUANLEITUNG - INSTRUCCIONES DE MONTAJE

DIMA DI FORATURA  
TEMPLATE  
GARBARIT DE PERCAGE  
SCHABLONEN  
PLANTILLA DE TALADRO

**11**  
  
**DADO A.B. M6**  
BOLT M6  
ECROU M6  
MÜTTER M6  
TUERCA M6  
**Q.TY n.4**

