

Assembly instructions



Motodome® Folding Garage | Order no. 10008325

Thank you for purchasing the Motodome Folding Garage: protecting motorcycles, scooters and ATV/quads from the elements.

Components supplied: 2 side members, each with 6 straight poles premounted on the inside and 1 strut premounted on the outside; 1 plate to connect the side members; 2 short connecting tubes; 10 long connecting tubes; 7 C-poles; 1 bag of bolts, nuts and washers (which may be premounted, depending on the model); 4 large ground anchors and 3 small screw anchors; 1 metal plate with ring; 1 polypropylene/cotton shell; 1 carabiner.

Before use, please compare the dimensions of the folding garage with the dimensions of your motorcycle. Vehicles with high windshields might not fit into the folding garage, and top boxes generally have to be taken off. The folding garage can also be used to store garden furniture, garden tools and bicycles out of the weather.

Please follow these assembly and safety instructions to ensure proper assembly and safe use and to keep your folding garage in good condition for longer.

Assembly: Set up the folding garage on solid ground in a sheltered spot on your property.

It is essential to fix the folding garage to the ground (concrete/

asphalt; not loose ground) with the anchors supplied to protect it from the wind.

Before assembly, we recommend you apply a hard-wax paint conditioner to all metal parts to protect them against corrosion. First, connect the two side members with the plate (**Fig. 1**). On each side, insert two short M6 bolts with washers and nuts and tighten them. Then attach the front C-pole to the front of the frame using two medium-long M6 bolts on the left and right – ensure that the piece of rubber in the middle of the C-pole is facing down (**Fig. 2**). Now take the two struts attached to the outside of the side members and secure them to the second inner straight pole on each side, using the long M6 bolts (**Fig. 3**).

The first inner straight pole on each side is later used to support the ventilation hood of the folding garage; the C-pole must not be connected to them until the shell has been put on. A short connecting tube is now put on the second inner straight pole on each side; the long connecting tubes are put on the third to sixth poles on each side (**Fig. 4**).

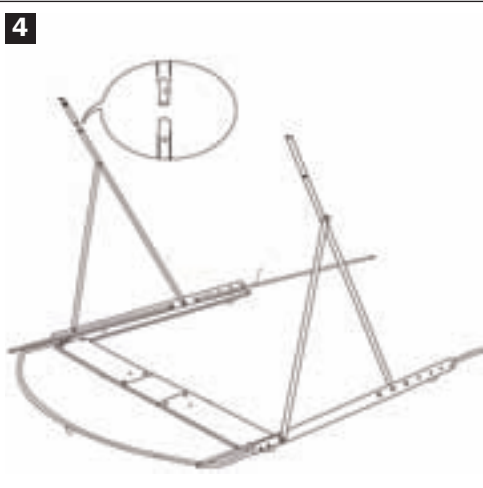
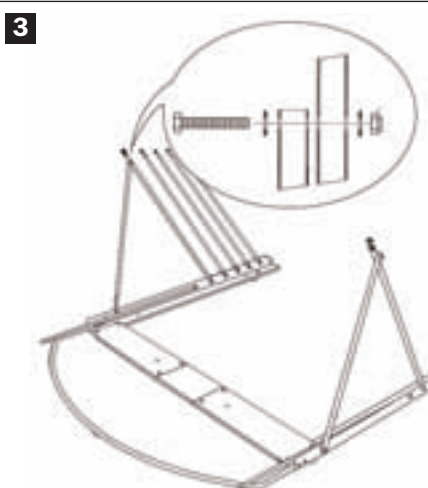
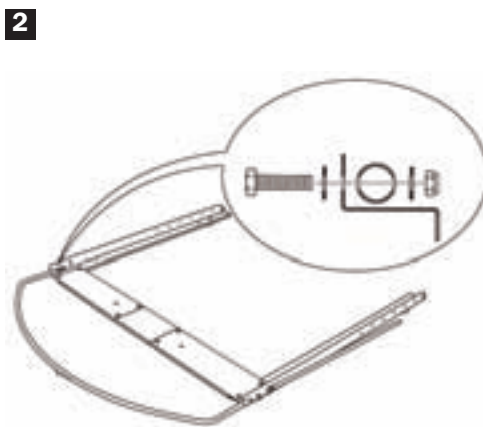
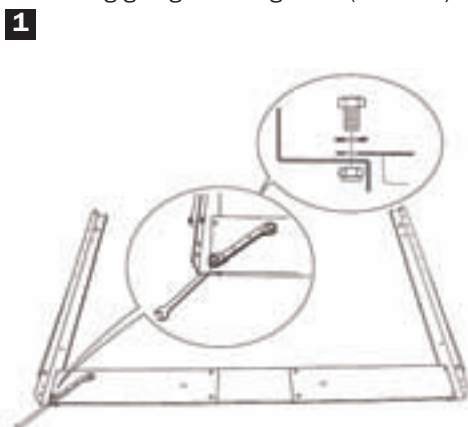

If you have any questions regarding the product and these instructions, please contact our technology centre using the following contact details before installing the product respectively before using the product for the first time: fax number 004940-734193-58 respectively email: technikcenter@louis.de.

We will be happy to provide you with quick support. This way, we jointly ensure that the product is installed and used properly.

Motodome® Folding Garage | Order no. 10008325

Next, mount the remaining C-poles (**Fig. 5**). The shell is then put on from the front. You start by fixing it to the second C-pole with three velcro fasteners. Then insert the poles for the ventilation hood through the slit provided in the material on each side, after which you can fix the shell to the bottom front C-pole with the velcro tunnel (**Fig. 6**). Continue by attaching the shell to the third to sixth C-poles; the latter is secured with the velcro tunnel. Now you can put the C-pole for the ventilation hood onto the straight poles and pull the ventilation hood over it. Draw the tension straps through the eyelets on the bottom left and right sides, and tighten them slightly. Then secure the shell to the frame at four points using straps.

Before fixing the folding garage to the ground, using two large anchors on each side, it must be moved to its final position. Lastly, the Z-shaped bracket for securing the folding garage is screwed on at the "hood" end and fastened to the ground with a small screw anchor (**Fig. 7**). To fix the "door" end of the garage to the ground, the metal plate with ring is secured with two small screw anchors. The folding garage can now be locked with the carabiner or a padlock (e.g., from the Louis range of products) (**Fig. 8**).

5



6

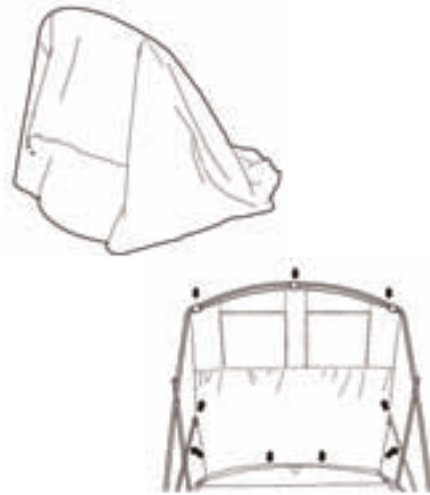

7

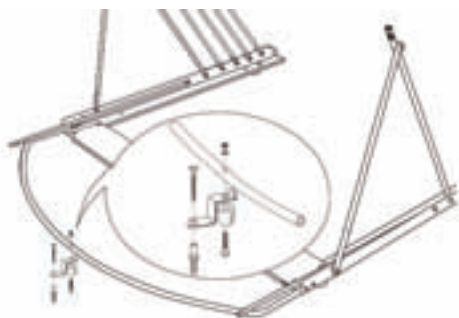

8

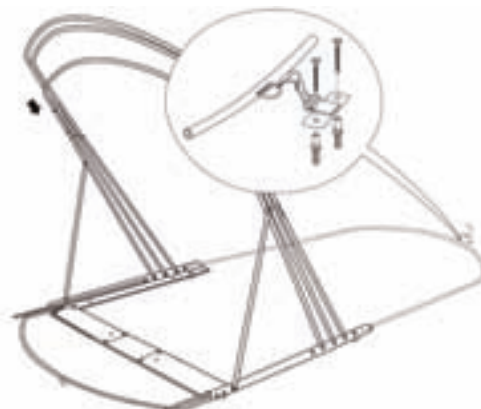

If you have any questions regarding the product and these instructions, please contact our technology centre using the following contact details before installing the product respectively before using the product for the first time: fax number 004940-734193-58 respectively email: technikcenter@louis.de.

We will be happy to provide you with quick support. This way, we jointly ensure that the product is installed and used properly.

Exclusive distribution: Detlev Louis Motorradvertriebs GmbH - 21027 Hamburg - Germany - www.louis.eu - E-Mail: technikcenter@louis.de

Version 09/10

Assembly instructions

Motodome

Motodome® Folding Garage | Order no. 10008325



Care: All metal parts of the folding garage should be protected against corrosion with a hard-wax paint conditioner. The shell can be cleaned with a garden hose or using a sponge and mild soapy water. Spraying with a textile impregnation agent makes it dirt-repellent.

Safety instructions: Only set up the folding garage on solid ground (concrete, slabs, asphalt), and never on loose soil, sand or grass. Always pick a sheltered spot (e.g., by a wall which acts as a windbreak). Always take measurements to check that the object you intend to store in the folding garage will fit. Do not use the folding garage as a tent. Do not park freshly painted vehicles in the folding garage. Note that the folding garage has a much larger wind surface area than an uncovered bike. It is important to secure the folding garage to the ground using ground anchors so that strong winds will not blow it away. Also, always secure the ends to the ground so that the wind cannot lift them.

Ensure that the objects placed in the folding garage do not come into contact with the poles or the shell, even when the folding garage moves in the wind. Ensure that all objects parked in the folding garage stand firm and cannot fall over.

Check once a week that the folding garage is secure and is safely anchored to the ground. Take it down in high winds or if a storm warning is issued. The manufacturer's guarantee does not cover damage resulting from acts of nature (e.g., storm or hail damage) or negligence.

Since this is a universal product and not intended just for one particular vehicle, it is important to make sure that it is suitable for your type of vehicle before you use the product for the first time. Always follow the directions of the vehicle manufacturer. This is essential, as improper use of this product or its unsuitability for a vehicle could affect the safety and/or condition of the vehicle.

If you have any questions regarding the product and these instructions, please contact our technology centre using the following contact details before installing the product respectively before using the product for the first time: fax number 004940-734193-58 respectively email: technikcenter@louis.de.

We will be happy to provide you with quick support. This way, we jointly ensure that the product is installed and used properly.

Exclusive distribution: Detlev Louis Motorradvertriebs GmbH - 21027 Hamburg - Germany - www.louis.eu - E-Mail: technikcenter@louis.de

Version 09/10